

CHESNEYS

GAS EFFECT STOVES STANDARD, LARGE & LOG BURNER OPTION

INSTALLATION & USER MANUAL

IMPORTANT:

PLEASE ENSURE YOU REGISTER FOR YOUR EXTENDED WARRANTY. PLEASE SEE PAGE 78 & 79 FOR DETAILS

www.chesneys.co.uk

Technical Manual
Technical PIN: 0359CS1578

User and Installation Instructions

Model No.

Standard Gas Stoves:

Salisbury

Beaumont

Shoreditch (Available at a later date)

Shoreditch LS (Available at a later date)

Shoreditch XLS (Available at a later date)

Large Gas Stoves:

Salisbury

Beaumont

Shoreditch (Available at a later date)

Belgravia (Available at a later date)

Shipton (Available at a later date)

Large Gas Log Stoves:

Salisbury

Beaumont

Shoreditch (Available at a later date)

Belgravia (Available at a later date)

Shipton (Available at a later date)

IMPORTANT:

**Please read these instructions
carefully before installation or use.**

**These instructions are only valid if the
following country code is on the appliance.**

**This appliance must be installed and serviced by a qualified
person in accordance with local and national regulations.**

**The flue system must be installed and inspected by a qualified
person in accordance with local and national regulations.**

Contents

Section	Pages
1 Unpacking	5-6
2 Technical Data	7-10
3 Installation Parameters	11-13
4 Burner and Control Information	14-17
5 Construction Information	18-30
6 Appliance Details	31
7 Preparing the Appliance for Installation	32
8 Installation	33-37
9 Placement of Fibre Logs, Chippings and Embers	38-46
10 Commissioning the Fire Unit	47-49
11 Briefing and Handover to the Customer	50
12 Servicing and Maintenance	51-52
13 Fault Finding	53-55
14 User Instructions	56-59
15 Control System Information	60-70
16 Annex A: Balanced Flue Conversion	71-73
17 Installer Commissioning Checklist	74
18 Dealer and Installer Information	75
19 Annual Service Record	76-77
20 Chesneys Warranty Information and Registration	78-79

1. Unpacking

Remove the appliance from its packaging, check that it is complete and undamaged.

If satisfied by the condition and the contents is as specified, proceed with the installation.

The installation should only be carried out by a competent person and all gas work must be carried out by a Gas Safe registered person in accordance with national and local regulations for both gas and electricity (If required).

The installation must comply with local and national building regulations.

For the Republic of Ireland, reference should be made to IS813 and ICP3 and any guidance notes from Board Gais.

Failure to comply with the regulations nullifies ALL guarantees.

Parts:

Fig.1 Gas Stove Appliance

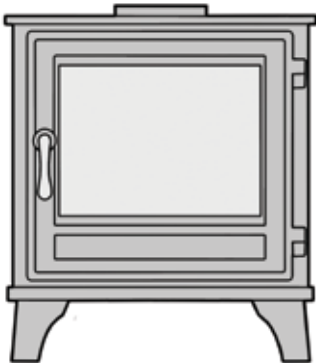

Fig.2 Installation Manual / Warning Label



Fig.3 Burner Assembly

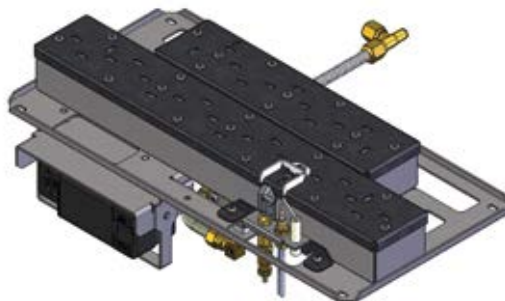

Fig.4 Logs

Standard Stove



Large Stove



Large Stove - Log Burner



Fig.5 Bag of embers



Fig.6 Remote Control Handset



Fig.7 Stainless steel panels



Fig.8 Glow strands



2. Technical Data

Gas Connection Size	8.0mm O.D. tubing
Control System	TESC (Thermo Electric Safety Control)
Appliance Mass Range (kilograms)	79kg – 155kg

Gas Type	Gas Category, Type and Supply Pressure	Countries of Destination															
		AT	BE	BG	CH	CY	CZ	DE	DK	EE	ES	FI	FR	GB	GR	HU	HR
NG	I _{2H} - G20 at 20mbar	✓		✓	✓		✓		✓	✓	✓	✓		✓	✓		✓
	I _{2E} - G20 at 20mbar							✓									
	I _{2E+} - G20 G25 at 20/25mbar		✓										✓				
	I _{2ELL} - G25 at 20mbar							✓									
LPG	I _{3B/P(30)} - G30/G31 at 30mbar			✓	✓	✓			✓	✓		✓	✓	✓	✓	✓	✓
	I ₃₊ - G30/G31 at 30/37mbar		✓		✓	✓	✓				✓		✓	✓	✓		
	I _{3P(50)} - G31 at 50mbar	✓					✓	✓									
	I _{3P(37)} - G31 at 37mbar		✓		✓		✓				✓		✓	✓	✓		✓
	I _{3P(30)} - G31 at 30mbar											✓					

Gas Type	Gas Category, Type and Supply Pressure	Countries of Destination														
		IE	IT	LT	LJ	LV	MT	NL	NO	PL	PT	RO	SE	SI	SK	TR
NG	I _{2H} - G20 at 20mbar	✓	✓	✓		✓			✓		✓		✓	✓	✓	✓
	I _{2E} - G20 at 20mbar				✓				✓		✓					
	I _{2L} - G20 G25 at 25mbar							✓								
	I _{2EK} - G25.3 at 25mbar							✓								
LPG	I _{3B/P(30)} - G30/G31 at 30mbar		✓	✓			✓	✓	✓			✓	✓	✓	✓	✓
	I ₃₊ - G30/G31 at 30/37mbar	✓	✓	✓						✓				✓	✓	✓
	I _{3P(50)} - G31 at 50mbar							✓							✓	
	I _{3P(37)} - G31 at 37mbar	✓	✓	✓				✓		✓	✓			✓	✓	✓
	I _{3P(30)} - G31 at 30mbar							✓				✓				

STANDARD GAS STOVE CONVENTIONAL FLUE

Gas Type	Gas Category, Type and Supply Pressure	Heat Input Gross kW	Heat Input Nett kW	Gas Rate m ³ /h	Burner Pressure	Injector marking	Pilot Assembly	Efficiency Class	NOx Class
NG	I _{2H} - G20 at 20mbar	5.3	4.8	0.49	18.5	320	SIT 9043 or ERTA PG-82-330	1	4
	I _{2E} - G20 at 20mbar	5.3	4.8	0.49	18.5				
	I _{2E+} - G20/G25 at 20/25mbar	5.3/5	4.8/4.5	0.49/0.53	18.5/23.6				
	I _{2ELL} - G25 at 20mbar	4.4	4	0.47	18.5				
	I _{2L} - G25 at 25mbar	5	4.5	0.53	23.6				
	I _{2EK} - G25.3 at 25mbar	5	4.5	0.53	23.6				
LPG	I _{3B/P(30)} - G30/G31 at 30mbar	5	4.6	0.14	28	140	SIT 9228 or ERTA PG-82-350	1	4
	I ₃₊ - G30/G31 at 30/37mbar	4.5/5	4.2/4.6	0.17/0.185	28/36				
	I _{3P(50)} - G31 at 50mbar	5	4.6	0.185	36				
	I _{3P(37)} - G31 at 37mbar	5	4.6	0.185	36				
	I _{3P(30)} - G31 at 30mbar	4.5	4.2	0.17	28				

STANDARD GAS STOVE BALANCED FLUE

Gas Type	Gas Category, Type and Supply Pressure	Heat Input Gross kW	Heat Input Nett kW	Gas Rate m ³ /h	Burner Pressure	Injector marking	Pilot Assembly	Efficiency Class	NOx Class
NG	I _{2H} - G20 at 20mbar	5.3	4.8	0.49	18.5	320	G30-ZP 312 (31.2 INJ)	1	4
	I _{2E} - G20 at 20mbar	5.3	4.8	0.49	18.5				
	I _{2E+} - G20/G25 at 20/25mbar	5.3/5	4.8/4.5	0.49/0.53	18.5/23.6				
	I _{2ELL} - G25 at 20mbar	4.4	4	0.47	18.5				
	I _{2L} - G25 at 25mbar	5	4.5	0.53	23.6				
	I _{2EK} - G25.3 at 25mbar	5	4.5	0.53	23.6				
LPG	I _{3B/P(30)} - G30/G31 at 30mbar	5	4.6	0.14	28	140	G30-ZP 2-271 (27.1 INJ)	1	4
	I ₃₊ - G30/G31 at 30/37mbar	4.5/5	4.2/4.6	0.17/0.185	28/36				
	I _{3P(50)} - G31 at 50mbar	5	4.6	0.185	36				
	I _{3P(37)} - G31 at 37mbar	5	4.6	0.185	36				
	I _{3P(30)} - G31 at 30mbar	4.5	4.2	0.17	28				

LARGE GAS STOVE CONVENTIONAL FLUE									
Gas Type	Gas Category, Type and Supply Pressure	Heat Input Gross kW	Heat Input Nett kW	Gas Rate m ³ /h	Burner Pressure	Injector marking	Pilot Assembly	Efficiency Class	NOx Class
NG	I _{2H} - G20 at 20mbar	6.9	6.2	0.64	13.2	Front 280	SIT 9043 or ERTA PG-82-330	1	4
	I _{2E} - G20 at 20mbar	6.9	6.2	0.64	13.2				
	I _{2E+} - G20/G25 at 20/25mbar	6.9/6.5	6.2/5.9	0.64/0.675	13.2/16.6				
	I _{2ELL} - G25 at 20mbar	5.7	5.1	0.6	13.4	Rear 120			
	I _{2L} - G25 at 25mbar	6.5	5.9	0.675	16.6				
	I _{2EK} - G25.3 at 25mbar	6.5	5.9	0.675	16.6				
LPG	I _{3B(P)(30)} - G30/G31 at 30mbar	6.9	6.4	0.195	27	Front 120	SIT 9228 or ERTA PG-82-350	1	4
	I ₃₊ - G30/G31 at 30/37mbar	6.2/6.9	5.7/6.4	0.229/0.254	28/35				
	I _{3P(50)} - G31 at 50mbar	6.9	6.4	0.254	35	Rear 80			
	I _{3P(37)} - G31 at 37mbar	6.9	6.4	0.254	35				
	I _{3P(30)} - G31 at 30mbar	6.2	5.7	0.229	28				

LARGE GAS STOVE BALANCED FLUE									
Gas Type	Gas Category, Type and Supply Pressure	Heat Input Gross kW	Heat Input Nett kW	Gas Rate m ³ /h	Burner Pressure	Injector marking	Pilot Assembly	Efficiency Class	NOx Class
NG	I _{2H} - G20 at 20mbar	6.9	6.2	0.64	13.2	Front 280	SIT 9043 or ERTA PG-82-330	1	4
	I _{2E} - G20 at 20mbar	6.9	6.2	0.64	13.2				
	I _{2E+} - G20/G25 at 20/25mbar	6.9/6.5	6.2/5.9	0.64/0.675	13.2/16.6				
	I _{2ELL} - G25 at 20mbar	5.7	5.1	0.6	13.4	Rear 180			
	I _{2L} - G25 at 25mbar	6.5	5.9	0.675	16.6				
	I _{2EK} - G25.3 at 25mbar	6.5	5.9	0.675	16.6				
LPG	I _{3B(P)(30)} - G30/G31 at 30mbar	6.9	6.4	0.195	27	Front 120	SIT 9228 or ERTA PG-82-350	1	4
	I ₃₊ - G30/G31 at 30/37mbar	6.2/6.9	5.7/6.4	0.229/0.254	28/35				
	I _{3P(50)} - G31 at 50mbar	6.9	6.4	0.254	35	Rear 80			
	I _{3P(37)} - G31 at 37mbar	6.9	6.4	0.254	35				
	I _{3P(30)} - G31 at 30mbar	6.2	5.7	0.229	28				

V2 LARGE GAS LOG STOVE CONVENTIONAL FLUE

Gas Type	Gas Category, Type and Supply Pressure	Heat Input Gross kW	Heat Input Nett kW	Gas Rate m ³ /h	Burner Pressure	Injector marking	Pilot Assembly	Efficiency Class	NOx Class
NG	I _{2H} - G20 at 20mbar	6.9	6.2	0.64	16.5	Centre Burner 120	SIT 9043	1	4
	I _{2E} - G20 at 20mbar	6.9	6.2	0.64	16.5				
	I _{2E+} - G20/G25 at 20/25mbar	6.9/6.5	6.2/5.9	0.64/0.675	16.5/16.8	Log L/H 160	or		
	I _{2ELL} - G25 at 20mbar	5.7	5.1	0.6	16.5	Log R/H 160	ERTA PG-82-330		
	I _{2L} - G25 at 25mbar	6.5	5.9	0.675	19.8				
	I _{2EK} - G25.3 at 25mbar	6.5	5.9	0.675	19.8				
LPG	I _{3B/P(30)} - G30/G31 at 30mbar	6.9	6.4	0.2	23	Centre Burner 60	SIT 9228	1	4
	I ₃₊ - G30/G31 at 30/37mbar	6.2/6.9	5.7/6.4	0.229/0.254	23/33				
	I _{3P(50)} - G31 at 50mbar	6.9	6.4	0.254	33	Log L/H 100	or		
	I _{3P(37)} - G31 at 37mbar	6.9	6.4	0.254	33	Log R/H 100	ERTA PG-82-350		
	I _{3P(30)} - G31 at 30mbar	6.2	5.7	0.229	23				

V2 LARGE GAS LOG STOVE BALANCED FLUE

Gas Type	Gas Category, Type and Supply Pressure	Heat Input Gross kW	Heat Input Nett kW	Gas Rate m ³ /h	Burner Pressure	Injector marking	Pilot Assembly	Efficiency Class	NOx Class
NG	I _{2H} - G20 at 20mbar	6.9	6.2	0.64	16.5	Centre Burner 120	Polidoro 446.1385.24	1	4
	I _{2E} - G20 at 20mbar	6.9	6.2	0.64	16.5				
	I _{2E+} - G20/G25 at 20/25mbar	6.9/6.5	6.2/5.9	0.64/0.675	16.5/16.8	Log L/H 160			
	I _{2ELL} - G25 at 20mbar	5.7	5.1	0.6	16.5	Log R/H 160			
	I _{2L} - G25 at 25mbar	6.5	5.9	0.675	19.8				
	I _{2EK} - G25.3 at 25mbar	6.5	5.9	0.675	19.8				
LPG	I _{3B/P(30)} - G30/G31 at 30mbar	6.9	6.4	0.2	23	Centre Burner 60	Polidoro 446.1385.44	1	4
	I ₃₊ - G30/G31 at 30/37mbar	6.2/6.9	5.7/6.4	0.229/0.254	23/33				
	I _{3P(50)} - G31 at 50mbar	6.9	6.4	0.254	33	Log L/H 100			
	I _{3P(37)} - G31 at 37mbar	6.9	6.4	0.254	33	Log R/H 100			
	I _{3P(30)} - G31 at 30mbar	6.2	5.7	0.229	23				

3. Installation Parameters

This appliance must be installed in accordance with the rules in force, and used only in a sufficiently ventilated space. Consult instructions before installation and use of this appliance.

NOTE - Wear protective clothing when fitting or carrying works out on the appliance.

For your safety it is law that all gas appliances must be installed by a competent person.

The installation must be carried out in accordance with the relevant local and national specifications and comply with current Building Regulations.

Chesneys recommend the fitting of a Carbon Monoxide detector that conforms to EN 50291 wherever a gas appliance is installed.

Due to the unpredictability of the draught in existing flues and chimneys Chesneys recommends the use of a liner for this product in accordance with local and national regulations.

The use of leak detector around the gas valve is NOT recommended due to moisture being able to enter and damage the valve.

NOTE - The flue must not be shared with any other appliance.

If the chimney has been used for solid fuel, the chimney must be swept before installation.

The flue must be fitted in accordance with local and national regulations.

Damper plates or restrictor plates must not be fitted in the flue.

The flue must be inspected by a competent person and passed for use with the appliance.

It is advised that a flue specialist inspect the flue system on an annual basis to ensure that the flue system is sound and the combustion products outlet (terminal) is clear of obstruction.

The flue system should only be fitted to the appliance where the chimney serving the appliance:

- a) Has passed a flue flow test to ensure that the flue is sound and without leaks; and
- b) Has been swept if previously used for solid fuel.

IMPORTANT NOTE - Balanced Flue

The appliance is designed to fit numerous installation situations as listed in these installation instructions. However only flue approved by Chesneys for this appliance may be used. If the appliance is installed on non-Chesneys approved parts, Chesneys cannot guarantee or accept and responsibility for the proper and safe working of the appliance.

The flue system must be constructed from the appliance upwards, with all joints being fully locked and sealed using the Chesneys specified parts.

Do not install the appliance in a bathroom or a room that contains a bath or shower.

It is advised that provisions be made for the removal of the appliance without the need to dismantle the flue system.

Before the appliance is installed, the flue / chimney must be inspected to ensure that it is structurally sound and free from obstructions.

Ensure the builders opening and supports are made of non combustible and heat resistant material.

Do not cover the appliance and or do not wrap it in an insulation blanket or any other material.

Do not make any changes to the appliance.

The gas connection must be in accordance with local and national regulations.

The use of a gas detection device is preferred method when investigating all connections to the rear of the gas control valve. Please note the use of leak detector fluid around the gas control valve is NOT recommended due to moisture being able to enter and damage the valve.

Ventilation

GB current British Standard BS5440 appliances classified under 7kW (net) do not require permanent ventilation.

NOTE - Ventilation requirements in other countries may vary please consult with national regulations in your country.

WARNING - SPILLAGE MONITORING SYSTEM

The pilot light and flame sensing device fitted to this appliance is also an atmospheric sensing device, this is not adjustable and must not be put out of action. If the pilot light is damaged or faulty it should only be replaced with an original genuine unit supplied by Chesneys.

When using stone like materials and or plaster finishing, the chimney breast should dry for at least 6 weeks to prevent cracks.

The appliance is not fitted with an integral guard. It is recommended that a guard be used for the protection of young children, the elderly or infirm and also for normal use conforming to BS8423:2002, such that access to the hot appliance is minimised.

Do not place combustible materials directly in front of the appliance.

In case of a damaged or broken glass, do not use the appliance and isolate the gas to the appliance.

Clean the glass before you use the appliance in order to prevent dirt from burning on the glass.

All appliances are supplied with a metal data plate attached to it and must remain with the appliance for annual services.

The data plate is attached to the rear of the appliance (see fig.9)

NOTE: DO NOT attempt to remove the data plate while the appliance is HOT!

Fig.9a

THIS APPLIANCE MUST BE INSTALLED IN ACCORDANCE WITH THE RULES IN FORCE AND ONLY USED IN A SUFFICIENTLY VENTILATED SPACE. CONSULT INSTRUCTIONS BEFORE INSTALLATION AND USE OF THIS APPLIANCE.					
COUNTRIES OF DESTINATION AT, BE, BG, CH, CY, CZ, DE, DK, EE, ES, FI, FR, GB, GR, HU, HR, IE, IT, LT, MT, NL, NO, PL, PT, RO, SE, SI, SK, TR	CHESNEYS 194-204 Battersea Park Road, London, SW11 4ND Tel: 020 7627 1410 www.chesneys.co.uk			CE UK CA	
	LARGE GAS STOVE C/F LOG BURNER			0359-23	2575-23
MODEL: <input checked="" type="checkbox"/>	BEAUMONT	SALISBURY	SHOREDITCH	BELGRAVIA	SHIPTON
GAS CATEGORY, TYPE AND SUPPLY PRESSURE (NATURAL GAS)	HEAT INPUT (GROSS) KW	HEAT INPUT (NETT) KW	GAS RATE M ³ /H	BURNER PRESSURE MBAR	EFFICIENCY CLASS
I _{2H} , I _{2E} - G20 AT 20MBAR	6.9	6.2	0.64	16.5	1
I _{2E} - G20/G25 AT 20/25MBAR	6.9 / 6.5	6.2 / 5.9	0.64 / 0.675	16.5 / 16.8	
I _{2HLL} - G25 AT 20MBAR	5.7	5.1	0.6	16.5	
I _{2L} - G25 AT 25MBAR	6.5	5.9	0.675	19.8	
I _{2EL} - G25.3 AT 25MBAR	6.5	5.9	0.675	19.8	
SERIAL NUMBER:			PIN: 0359CR1578		
SPILLAGETEST TEST THE APPLIANCE FOR SPILLAGE AFTER AN INTRIAL 10 MINUTES OF OPERATION ON A MAXIMUM RATE. PLACE A SMOKE MATCH INSIDE OF THE THE DRAUGHT DIVERTER AT THE REAR OF THE APPLIANCE. THE SMOKE SHOULD BE DRAWN INTO THE APPLIANCE. IF SPILLAGE OCCURS TURN OFF THE APPLIANCE AND REFER TO THE INSTALLATION MANUAL.					

Fig.9b

THIS APPLIANCE MUST BE INSTALLED IN ACCORDANCE WITH THE RULES IN FORCE AND ONLY USED IN A SUFFICIENTLY VENTILATED SPACE. CONSULT INSTRUCTIONS BEFORE INSTALLATION AND USE OF THIS APPLIANCE.					
COUNTRIES OF DESTINATION AT, BE, BG, CH, CY, CZ, DE, DK, EE, ES, FI, FR, GB, GR, HU, HR, IE, IT, LT, MT, NL, NO, PL, PT, RO, SE, SI, SK, TR	CHESNEYS 194-204 Battersea Park Road, London, SW11 4ND Tel: 020 7627 1410 www.chesneys.co.uk			CE UK CA	
	LARGE GAS STOVE B/F LOG BURNER			0359-23	2575-23
MODEL: <input checked="" type="checkbox"/>	BEAUMONT	SALISBURY	SHOREDITCH	BELGRAVIA	SHIPTON
GAS CATEGORY, TYPE AND SUPPLY PRESSURE (NATURAL GAS)	HEAT INPUT (GROSS) KW	HEAT INPUT (NETT) KW	GAS RATE M ³ /H	BURNER PRESSURE MBAR	EFFICIENCY CLASS
I _{2H} , I _{2E} - G20 AT 20MBAR	6.9	6.2	0.64	16.5	1
I _{2E} - G20/G25 AT 20/25MBAR	6.9 / 6.5	6.2 / 5.9	0.64 / 0.675	16.5 / 16.8	
I _{2HLL} - G25 AT 20MBAR	5.7	5.1	0.6	16.5	
I _{2L} - G25 AT 25MBAR	6.5	5.9	0.675	19.8	
I _{2EL} - G25.3 AT 25MBAR	6.5	5.9	0.675	19.8	
SERIAL NUMBER:			PIN: 0359CR1578		
SPILLAGETEST TEST THE APPLIANCE FOR SPILLAGE AFTER AN INTRIAL 10 MINUTES OF OPERATION ON A MAXIMUM RATE. PLACE A SMOKE MATCH INSIDE OF THE THE DRAUGHT DIVERTER AT THE REAR OF THE APPLIANCE. THE SMOKE SHOULD BE DRAWN INTO THE APPLIANCE. IF SPILLAGE OCCURS TURN OFF THE APPLIANCE AND REFER TO THE INSTALLATION MANUAL.					

4. Burner and Control Information

Fig.10

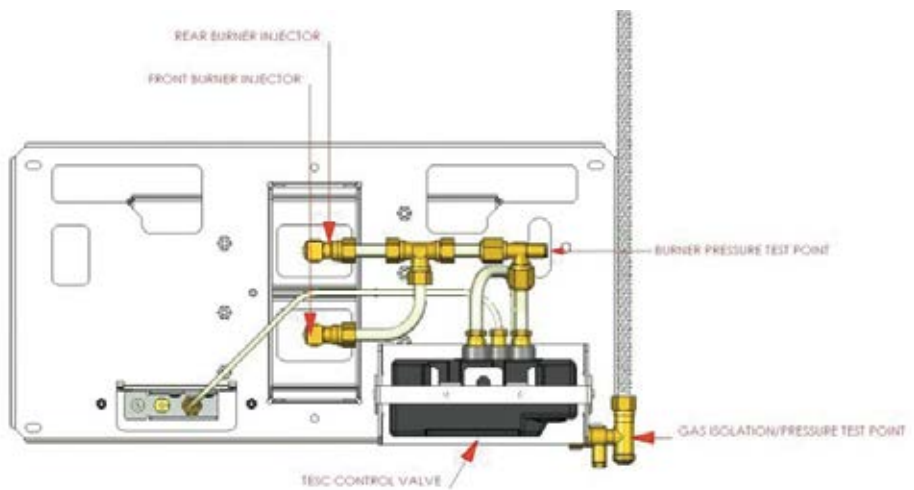
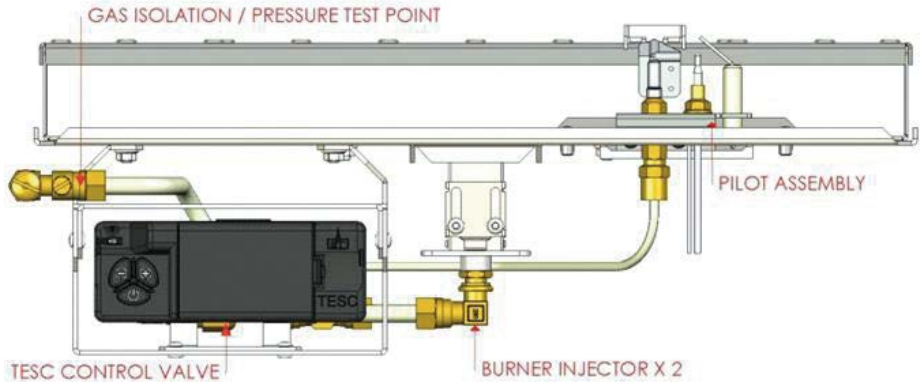

Dimensions

Fig.10a S8 CF Std

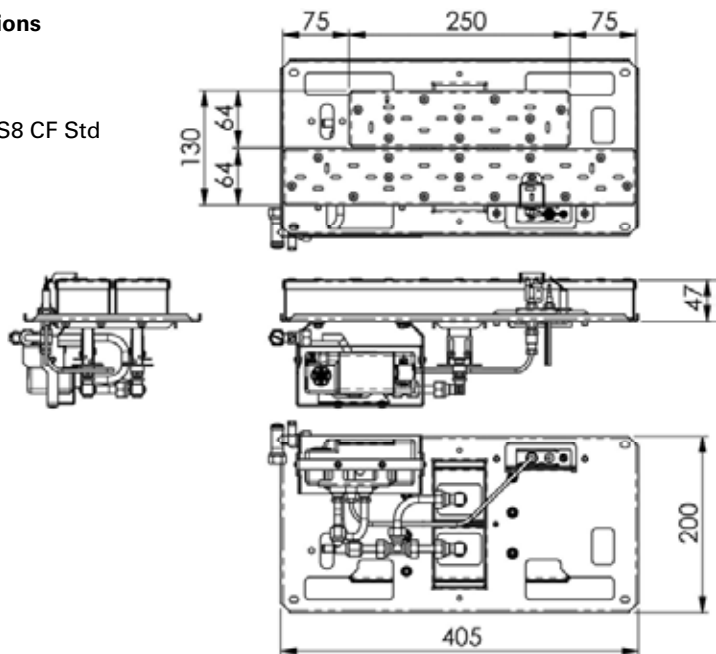

Fig.10b S8 CF Log

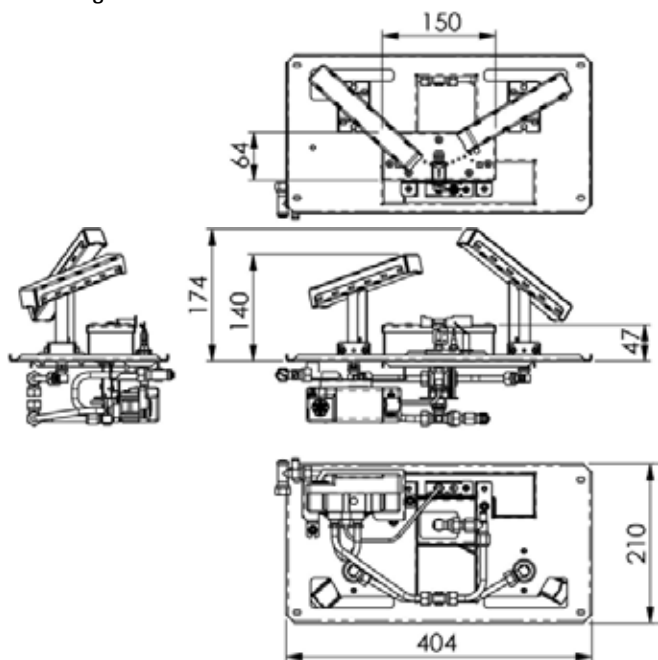

Fig.10c S8 BF Std

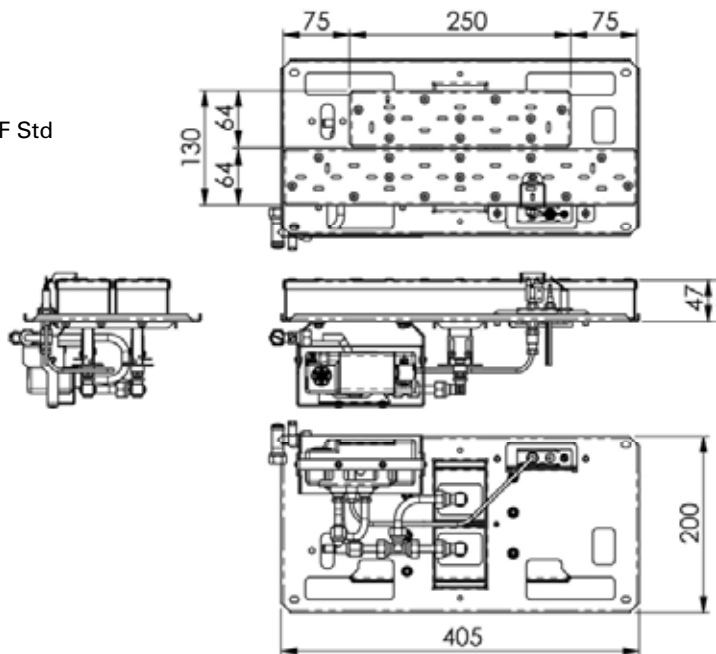
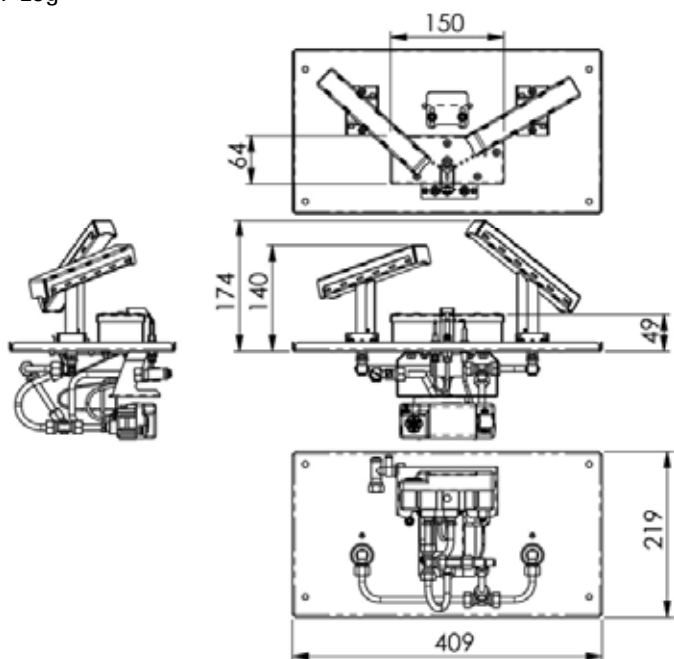

Fig.10d S8 BF Log



Burner Control Systems

Fig.11

1. THERMACO - THERMO ELECTRIC SAFETY CONTROL (TESC)

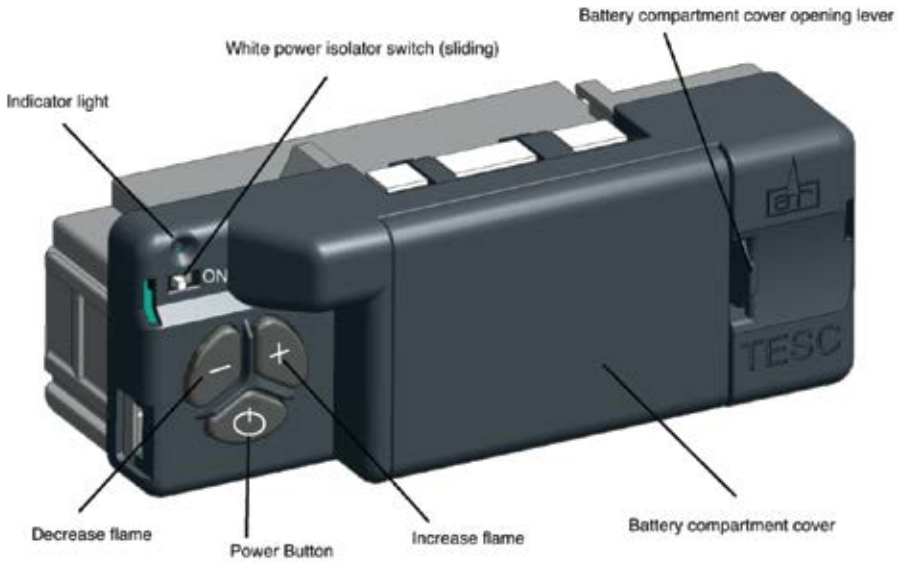

PILOT ASSEMBLY SITTING



HANDSET RADIO FREQUENCY

5. Construction Information

Hearths

A hearth shall be provided according to National regulations, in Great Britain this would be to Building Regulation Document J and BS5871-1. A Hearth shall be provided for the stove extending to at least the front of the supporting legs, and to at least each side of the stove. The edge of the hearth should be marked to provide a warning to the building occupants and to discourage combustible floor finishes such as carpet being laid too close to the appliance. A way of achieving this would be to provide a change in level.

Chesneys recommend a hearth footprint 50mm more on all 4 sides than the footprint of the appliance. The hearth shall have a minimum thickness of 12mm.

Emissions Exit Connection Types:

1. Conventional Flue
2. Balanced Flue

Conventional Flue

A smoke pellet can be used to test the flue for effectiveness of the draw, light the smoke pellet and place to the base of the chimney/liner. Check other parts of the dwelling (including loft areas) for leakage, down draught etc. If the smoke is drawn into the chimney/liner without problem, continue with the installation.

If there is little or no flow into the chimney preheat the chimney and repeat the smoke test. If there are still issues with the draw seek expert advice.

NOTE –The smoke test gives a fair idea on the draw, but is no guarantee that the products of combustion from the appliance will clear. A spillage test is also required after the installation.

If spillage occurs after installation contact the manufacturer for advice.

The appliance is designed to be installed into a Class 1 Conventional flue system that has been lined with a minimum 4" flue liner, or a factory made flue system conforming to BS 5440-1.

NOTE-The minimum flue liner is 3 meters from the spigot.

The maximum height should be governed by the draw on the individual flue during the effectiveness of smoke removal/testing of the flue.

Conventional Class 1 Chimney (lined only) / Factory made flue system conforming to BS 5440-1.

Fig.13 Installed into a chimney recess / builders opening.

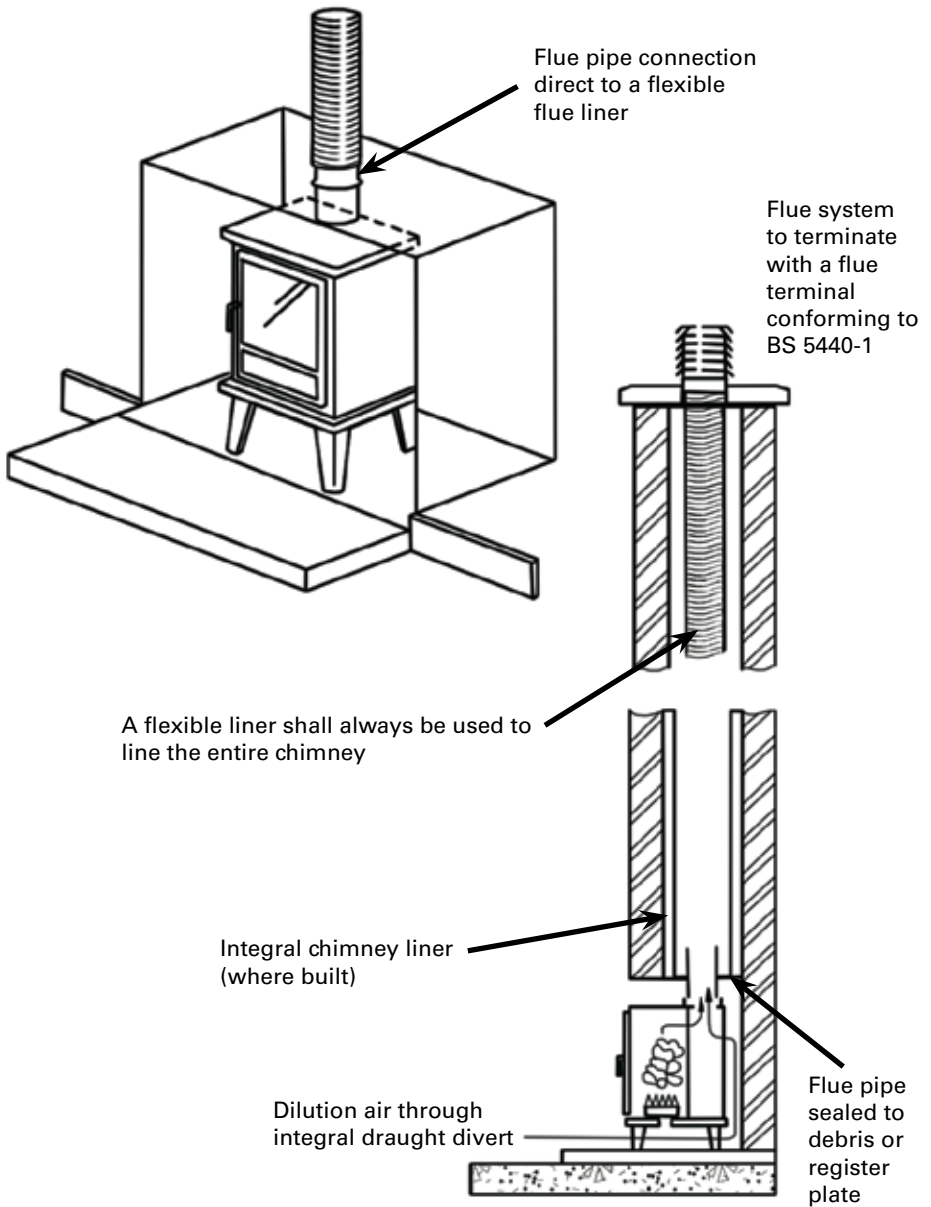
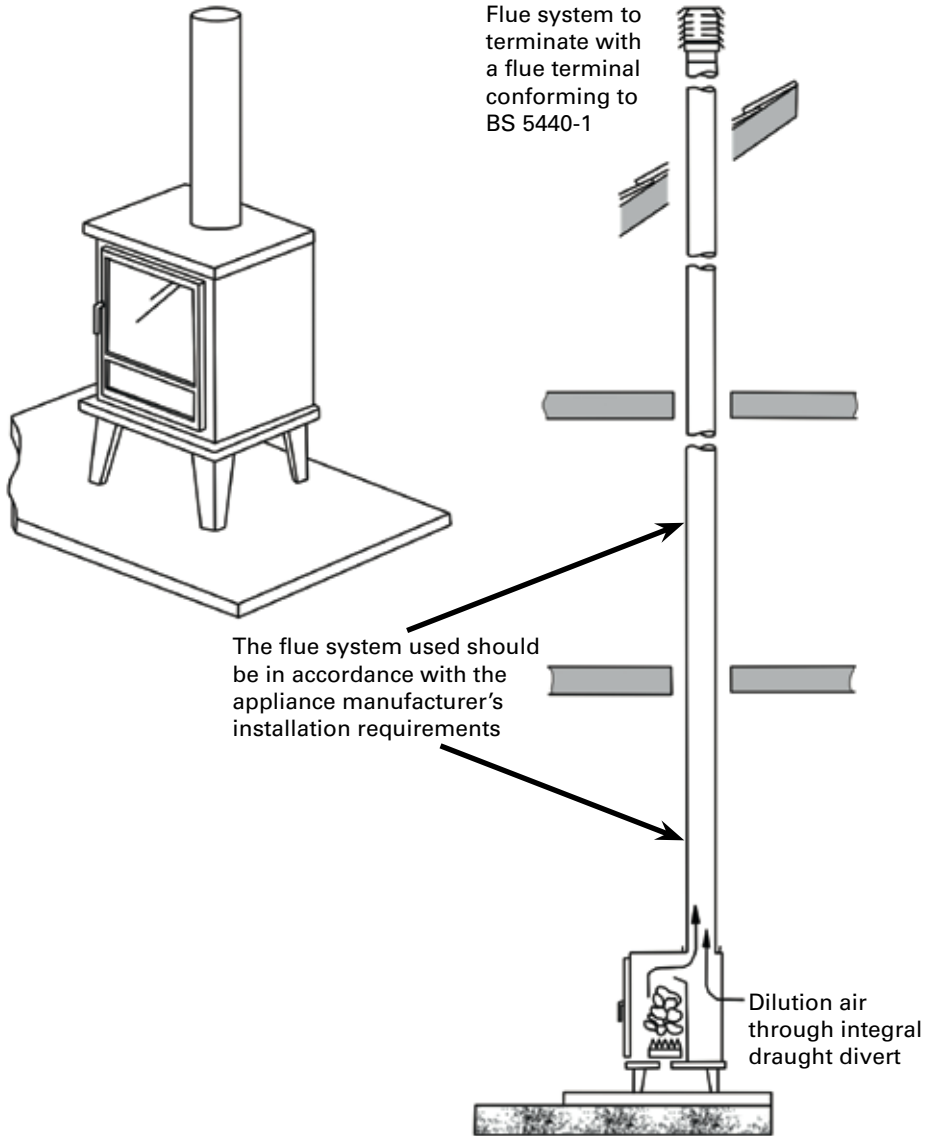

Fig.14 Free standing installation connected to a factory made flue system.



Flue & Chimney Requirements for a Chesneys Linerless Kit

- Make an assessment of the chimney ensuring it's clean and free of obstruction. If not the chimney must be swept prior to installation.
- Any restriction or damper plates must be either removed or locked in the permanently open position.
- Due care should be taken when using a linerless flue to prevent condensation forming. Do not fit a linerless flue kit in a chimney taller than 10 metres external wall or 12 metres internal wall.
- The required flue connection for this is 4" (100mm).
- **THESE STANDARDS SHOULD CONFORM TO BS 5440 Part 1.**

UNDER NO CIRCUMSTANCES MUST THE LINERLESS KIT BE USED WITH ANY INSTALLATION OTHER THAN AN EXISTING MASONRY CHIMNEY WHICH HAS A MINIMUM DIAMETER OF 178mm (7"). THE CHIMNEY MUST BE SOUND AND CLEAN. IF PREVIOUSLY USED FOR SOLID FUEL, IT MUST BE SWEEPED PRIOR TO PROCEEDING WITH THE INSTALLATION.

1 Metre Conventional Flue Connection

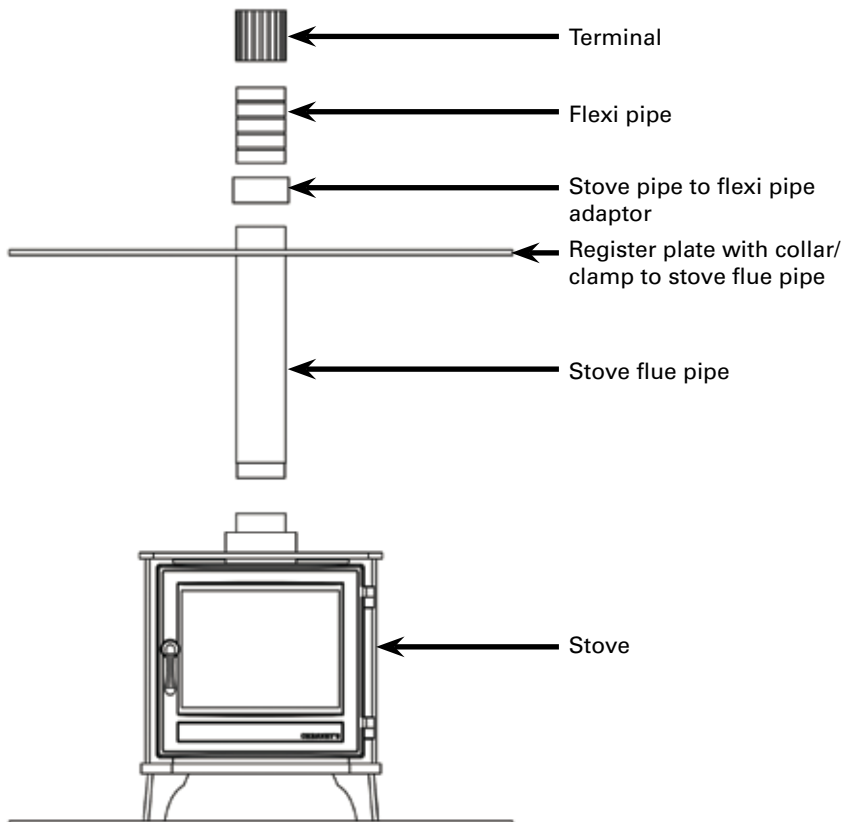

The Builders Opening

Use non combustible heat resistant materials for the chimney breast, including the top of the chimney breast, the material in the chimney breast and the back wall of the chimney breast. The construction must comply with all relevant regulations.

The appliance can be used with a sound Class 1 lined flue with a minimum 4" diameter. If the appliance is used with an existing lined chimney the minimum flue diameter must be 6" (152.4mm) or above to accommodate the 4" liner.

Balanced Flue installation

This appliance may be installed with a vertical terminal (C31) or a horizontal terminal (C11). This appliance may only be used with Balanced Flue (otherwise known as Concentric Flue) parts as specified by Chesneys. The Chesneys specified flue parts have been approved with the appliance. If the appliance is installed on non-Chesneys approved parts, Chesneys cannot guarantee or accept and responsibility for the proper and safe working of the appliance.

The flue system must be constructed from the appliance upwards, with all joints being fully locked and sealed using the Chesneys specified parts.

Chesneys products are approved for use with the following Flue System:

- Poujoulat Duogas.

Timber Frame Construction

Whilst it is possible to install room-sealed appliances in timber frame properties, great care needs to be taken to ensure that the flue assembly does not interfere with the weather proofing qualities of any outer wall which it may penetrate. Before attempting this work, further details need to be referenced, (e.g. "Gas Installations in Timber Frame Buildings" from the CORGI installer series in the UK).

Carport or Building Extension

Where a flue terminal is sited within a carport or building extension, it should have at least two completely open and unobstructed sides. The distance between the lowest part of the roof and the top of the terminal should be at least 600mm.

Note: A covered passageway should not be treated as a carport. Flues should not be sited in a covered passageway between properties.

Basements, Lightwells and Retaining walls

Flue terminals should not be sited within the confines of a basement area, light well or external space formed by a retaining wall, unless steps are taken to ensure the products of combustion can disperse safely at all times. It may be possible to install this Balanced Flue system in such a location provided that it is not sited lower than 1m from the top level of that area to allow combustion products to disperse safely.

Flue terminals should be sited to ensure total clearance of the combustion products in accordance with the included information. When the products of combustion are discharged, they should not cause a nuisance to adjoining or adjacent properties and they should be positioned so that damage cannot occur to other parts of the building. If the outer wall surface is constructed of combustible material, a non-combustible plate should be fitted behind the terminal projecting 25mm beyond the external edges of the terminal.

Terminal Locations

Fig.15

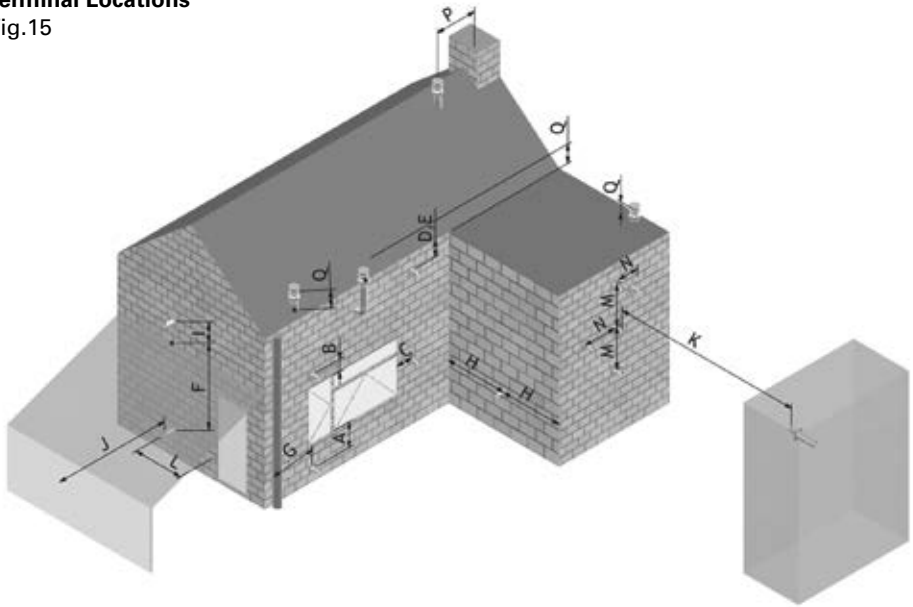

Dimension	Terminal Position	Distance (mm)
A*	Directly below an opening, air brick, opening window etc.	600
B	Above an opening, air brick, opening window etc.	300
C	Adjacent to an opening, air brick, opening window etc.	400
D	Below gutters, soil pipes or drain pipes	300
E	Below eaves	300
F	Below balconies of car port roof	600
G	From a vertical drain pipe or soil pipe	300
H	From an internal or external corner	600
I	Above ground roof or balcony level	300
J	From a surface facing the terminal	600
K	From a terminal facing the terminal	600
L	From an opening in the car port (e.g. door, window into the dwelling)	1200
M	Vertically from a terminal on the same wall	1500
N	Horizontally from a terminal on the same wall	300
P	From a vertical structure on the roof	600
Q	Above intersection with roof	150

* In addition, the terminal should not be nearer than 300mm to an opening in the building fabric formed for the purpose of accommodating a built in element such as a window frame.

Terminal Guards

The flue outlet should be protected with a terminal guard conforming to BS5440-1 if persons could come into contact with it, or if it could be damaged or if it is in a vulnerable position such as where the flue discharge is within easy reach from the ground (less than 2.1m) balcony, veranda or an opening window.

The balanced flued gas stoves are all supplied as a rear exit flue configuration, only the large gas stove can be converted to a top exit configuration. The balanced flue models will be supplied with the flue spigots and gaskets inside of the fire chamber and will need to be fitted as part of the installation. Please refer to Annex A for instruction on how to correctly fit the components .

For rear exit flue configuration:

Snorkel Horizontal Terminal.

IMPORTANT NOTE – If a terminal guard is required the snorkel terminal should be fitted with a guard that covers the entire terminal conforming to BS5440-1.

Fig.16

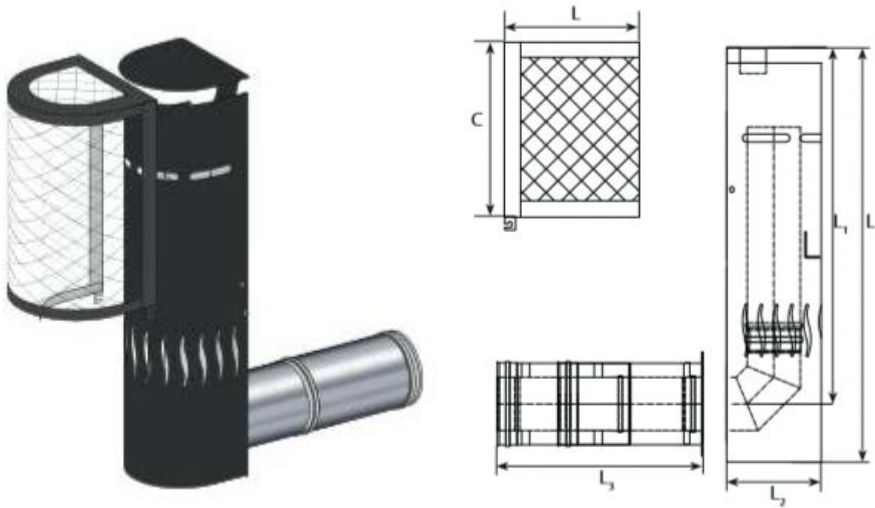

SNORKEL TERMINAL - C/W GUARD MESH & EXTENSION SECTION	
REF.	SNO 00 BIG
CODE	52 100 420
L	787
L ₁	677
L ₂	180
L ₃	350 to 550
C x L	333.5 x 256

Regarding some Installations it may be necessary to purchase additional flue components to facilitate none standard installations with the standard snorkel kit.

Horizontal Wall Vent Termination Type C₁₁

Flue sizing: Ø100/150 throughout.

Fig.17a

HORIZONTAL BALANCED FLUE CONFIGURATIONS

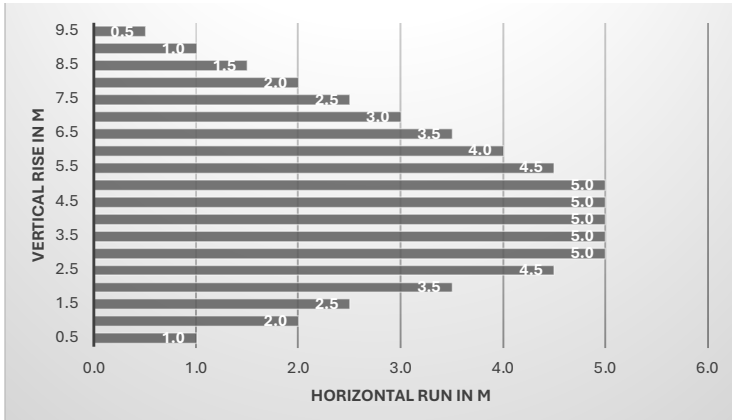

Fig.17b

VERTICLE RISE IN m	HORIZONTAL RUN IN m
0.5	1.0
1.0	2.0
1.5	2.5
2.0	3.5
2.5	4.5
3.0	5.0
3.5	5.0
4.0	5.0
4.5	5.0
5.0	5.0
5.5	4.5
6.0	4.0
6.5	3.5
7.0	3.0
7.5	2.5
8.0	2.0
8.5	1.5
9.0	1.0
9.5	0.5

Maximum pipe extension,
for outside wall.

Use shaded area to calculate maximum
allowable length
(H) for the corresponding pipe rise
(V) Minimum Vertical Flue Height: 0.5m

Horizontal Wall Vent Termination

Fig.18

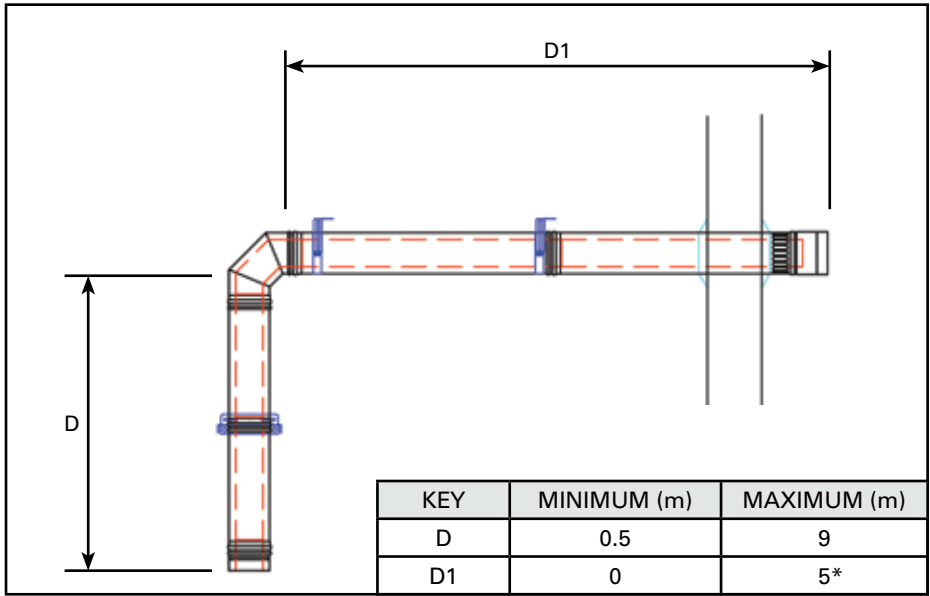

* Please note: the dimensions given in fig 17 must be adhered to calculate the maximum allowable length of D1 for the corresponding pipe rise D

Vertical Roof Vent Termination C₃₁

Flue sizing: Ø100/150 throughout - 0.5m minimum, 12m maximum flue length. When incorporating horizontal flue runs, these horizontal runs must be less than 0.5 times the overall flue height.

Fig.19

VERTICAL TERMINATION

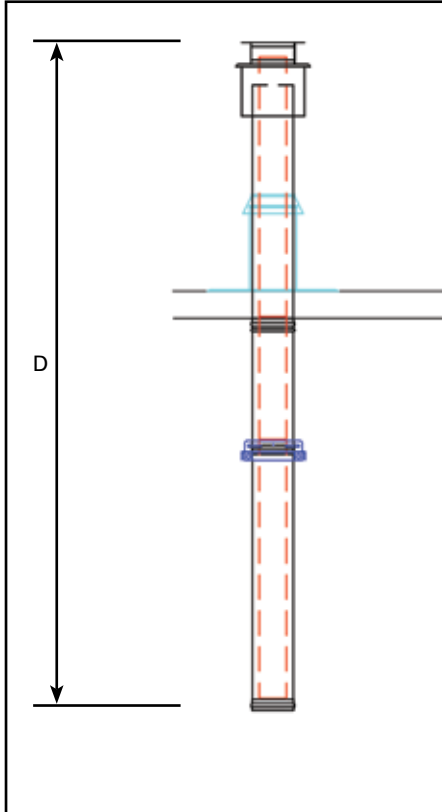

KEY	MINIMUM (m)	MAXIMUM (m)
D	0.5	12

VERTICAL WITH ANGLE TERMINATION

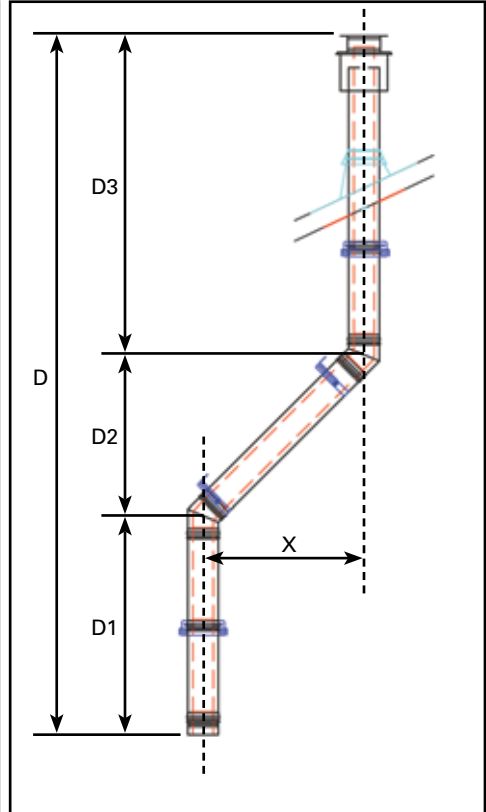

KEY	MINIMUM (m)	MAXIMUM (m)
D	1.2	12
D1	0.5	10
D2	0.2	10
D3	0.5	10
X	0	3

Fig.20

VERTICAL WITH ANGLE TERMINATION

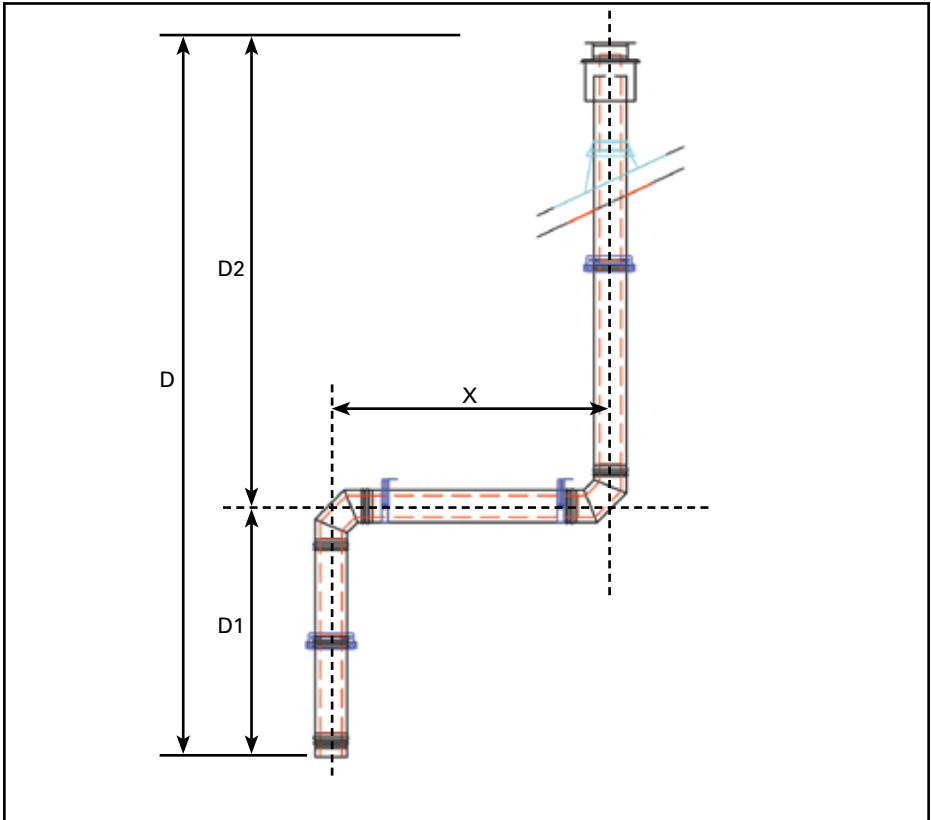

KEY	MINIMUM (m)	MAXIMUM (m)
D	1*	12
D1	0.5	10
D2	0.5	10
X	0	3

* D Minimum = 2x "X"

Fig.21

VERTICAL TERMINATION WITH EXISTING CHIMNEY

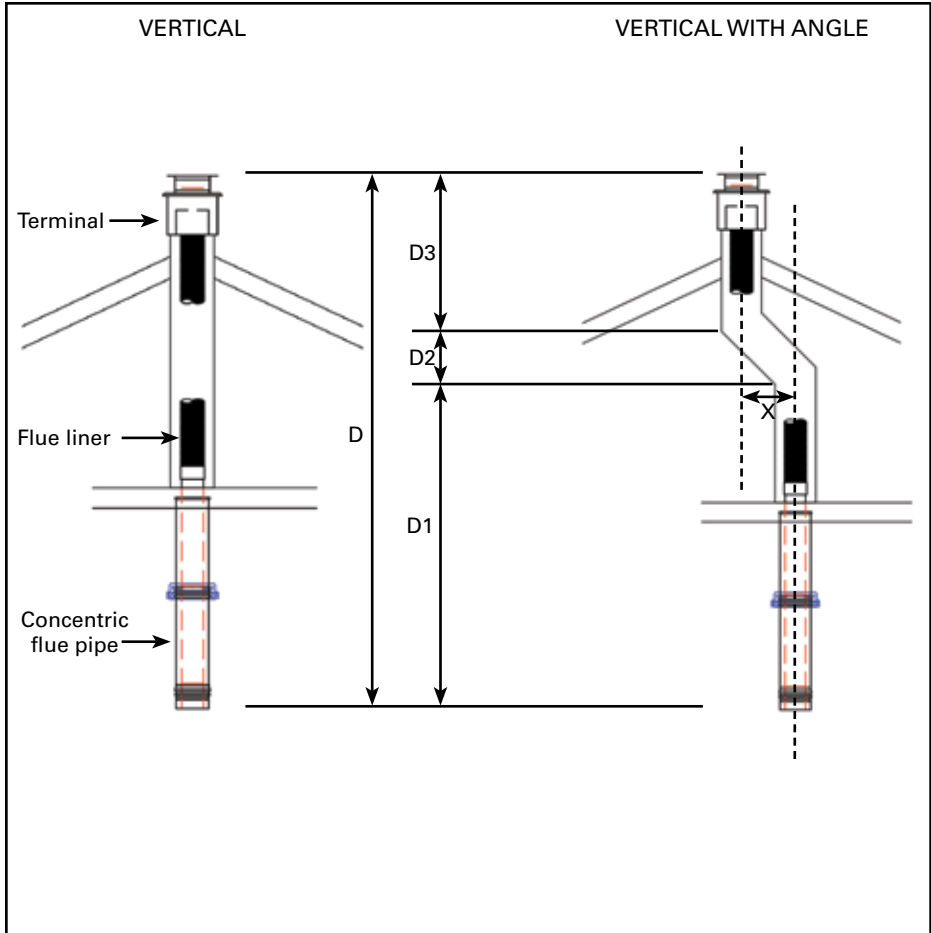

KEY	MINIMUM (m)	MAXIMUM (m)
D VERTICAL	1*	12
D VERTICAL WITH ANGLE	1.2	12
D1	0.5	10
D2	0.5	10
X	0	3

* D Minimum = 2x "X"

Appliance distances and clearances

The minimum distances to combustibles are given in the table below. Distances to non-combustibles should conform to local and national building regulations.

Due to the nature of the appliance most part of it will become hot during normal operation, therefore the entire appliance is classed as a working surface.

Standard Gas Stove	COMBUSTIBLES
Rear of appliance	100mm
Side of appliance	75mm
Above the appliance	200mm
Shelf height above appliance	300mm
MINIMUM CLEARANCE TO BE STRICTLY MAINTAINED AT REAR OF APPLIANCE TO NON-COMBUSTIBLE IS 50MM FOR CORRECT OPERATION AND AIR FLOW. IF THIS IS NOT ACHIEVABLE THE APPLIANCE MUST NOT BE INSTALLED!	

Large Gas Stove	COMBUSTIBLES
Rear of appliance	100mm
Side of appliance	75mm
Above the appliance	200mm
Shelf height above appliance	300mm
MINIMUM CLEARANCE TO BE STRICTLY MAINTAINED AT REAR OF APPLIANCE TO NON-COMBUSTIBLE IS 50MM FOR CORRECT OPERATION AND AIR FLOW. IF THIS IS NOT ACHIEVABLE THE APPLIANCE MUST NOT BE INSTALLED!	

Please Note: The depth of the shelf should not project more than 250mm from the front face of the fireplace opening.

Gas Route

For your safety it is law that all gas appliances must be installed by a competent person, in accordance with the current Gas Safety regulations applicable in the country of use.

Ensure that the gas supply is capable of delivering the required amount of gas, and is in accordance with the rules in force.

When laying the gas pipe work check the fire unit's gas inlet location to ensure a smooth run.

The gas inlet connection is located below the burner assembly. This can be accessed via the stove door. The pipe should run under the appliance and connect into the inlet connection of the 8mm fitting provided. The gas pipe can be routed from any direction below the appliance as the inlet connection is flexible to accommodate various positions.

An isolation valve or valves must be fitted near to the appliance in an accessible area, meeting all local and national regulations this is to allow the complete removal of the burner control assembly, for maintenance or repair.

6. Appliance Details

Fig.22 Appliance dimensions

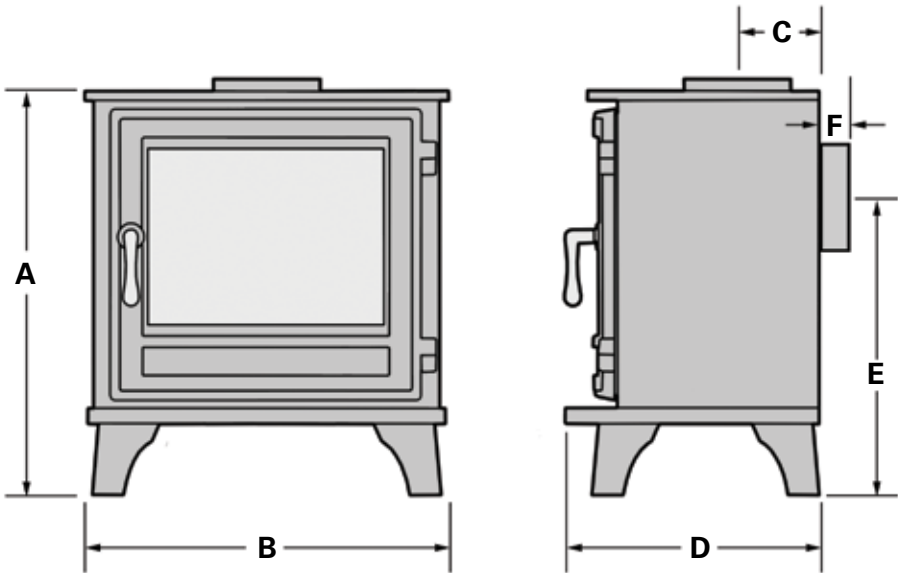

Standard Gas Stoves	A mm	B mm	C mm	D mm	E mm*	F mm**
Beaumont	552	535	108	307	395	40
Salisbury	534	482	108	335	395	40
Shoreditch	543	478	107	295	394	40

Large Gas Stoves	A mm	B mm	C mm	D mm	E mm*	F mm**
Beaumont	704	642	128	395	520	40
Salisbury	653	570	128	428	486	40

Notes:

* Dimension E centre of rear exit spigot for balanced flue models only.

** Dimension F rear spigot for balanced flue models only.

7. Preparing the Appliance for Installation

The appliance is supplied in separate boxes, stove, burner assembly, logs set. The stainless steel interior side panels are pre-fitted to the appliance. The installer is required to install the burner and logs into the appliance.

Important Notes

The balanced flue models will be supplied with the flue spigots and gaskets inside of the fire chamber and will need to be fitted as part of the installation. Please refer to Annex A for instruction on how to correctly fit the components.

Ensure the glass is clean on both sides before lighting as dirt, oils etc. can etch the glass.

Do not clean with abrasive materials as this can accelerate dirt accumulation and weaken the glass.

The appliance should be placed in the correct installation position, taking into account the flue connection and gas connection.

The door can be opened by turning the handle clockwise by a quarter of a turn and swing open.

Fig.23



The interior panels have been pre-fitted into the appliance, these must be inspected for any damage during transit. The stainless steel sides will patinate (mellow) over a period of time this can be cleaned with a hob type cleaner if a high reflection is preferred.

8. Installation

IMPORTANT Please ensure the gas pipe has been routed and the flue connection is terminated in a suitable position ready for connection.

Fixing of the appliance

The gas stove is a free standing appliance and does not require any additional fixing to the floor or walls.

Flue connection for conventional flue models only

Place the appliance in the installation position ensuring the top lid is installed. The appliance spigot should only be connected to a suitable flue system.

At this stage the decorative collar pipe should be cut to the desired length and positioned over the flue pipe, ensuring there is a clearance above that will allow the decorative collar to slide up to enable the access for connecting the flue pipe.

The flue pipe will need to be placed over the appliance spigot, ensuring a minimum insertion depth of 50mm. The joint between the flue pipe and the appliance spigot is to be sealed with a suitable high temperature sealant. Secure the flue in position using suitable self-tapping screws. The flue must be sealed to the appliance to ensure the products of combustion do not enter the room. Slide the decorative collar pipe down into its finished position.

Flue connection for balanced flue models only

The flue must be sealed to the appliance using a high temperature sealant. Apply a bead of sealant to the inner face of the outer flue collar and to the outer face of the inner flue pipe then attach the connecting flue system. The balanced flue models are supplied as a rear exit flue appliance. Only the Large gas stove can be adapted to top exit if required (details of this are contained in Annex A).

Gas Connection

NOTE – All gas work must be carried out by a qualified gas installer to all relevant regulations.

Ensure that the gas supply is capable of delivering the required amount of gas, and is in accordance with the rules in force.

An isolation valve or valves must be fitted near to the appliance in accordance with national regulations to allow the complete removal for maintenance or repair.

The appliance is supplied with a combined isolation/pressure test point valve, this is located on the front left hand side of the appliance, connect the gas inlet to the correct connection shown with 8mm rigid pipework.

Fig. 24

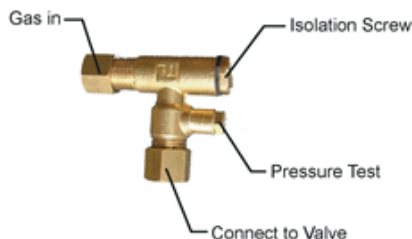

Fitting the burner for the Conventional Flue and Balanced Flue V1

Before connecting the fire unit ensuring the gas supply pipe has been terminated in a suitable position. Please ensure that the gas supply pipe has been purged from air and debris.

The grate assembly and log guard will need to be removed from the stove to allow for the installation of the burner.

Fig.25

- 1: Remove all items from the inside of the stove.



- 2: Fit the burner into the stove and secure with the 4 M6 screw fixings provided.



- 3: Fit the front grate assembly at the front of the chamber on top of the burner plate.



- 4: Fit the rear grate assembly at the rear of the chamber on top of the burner plate. The Large conventional Flue models will require the grates to be fixed using M5 countersunk screws provided.



- 5: Fit the log guard into the slots provided on the front grate assembly.



Before connecting the fire unit ensuring the gas supply pipe has been terminated in a suitable position. Please ensure that the gas supply pipe has been purged from air and debris.

The grate assembly and log guard will need to be removed from the stove to allow for the installation of the burner.

Fitting the Burner and Grates - Balanced Flue V2

1. Remove all items from inside the stove.



2. Fit the burner into the stove and secure with the 4xM6 fixings provided.



3. Fit the left grate assembly with the insert facing forward fix with M5 countersunk screws.



4. Fit the right grate assembly with the insert facing forward fix with M5 countersunk screws.



5. Fit the central burner grate assembly with the log retainer facing forward.



6. Fit the log guard into the slots provided on the front grate assembly.



7. Fit the pistol burners into slots located on the central grate assembly.



Fitting the Burner and Grates - Conventional Flue V2

1. Remove all items from inside the stove.

Please note: The grates supplied in the stove will not be suitable for the version 2 burner, please use alternative grates supplied.



2. Fit the two side brackets in to the stove with fittings provided.

Please note: These shelves may already be installed in some models.



3. Fit the burner onto side brackets and remove isolation valve for ease.

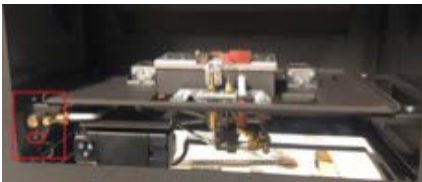

4. Fit the burner into the stove and secure with the 4xM6 fixings provided.



5. Fit the side retaining brackets using 4 x M6 fixings

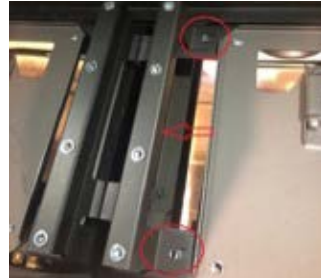

6. Fit the left and right grate assemblies with inserts facing forward.



7. Fit the central burner grate assembly with the log retainer facing forward.



8. Fit the log guard into the slot provided on the front grate assembly.



9. Fit the pistol burners into slots located on the central grate assembly.



Fig.26

Connect the main gas valve inlet either directly to the gas isolation valve or via the flexible gas pipe using a suitable coupling as shown in below.



Soundness testing

At this stage gas soundness test can be performed, connect a suitable test meter to the pressure test point ensuring the tube is routed under the main body of the appliance and not through the door. Carry out a soundness test, on completion leave the meter connected.

IMPORTANT

Only continue with the installation if soundness performance is satisfactory.

Inlet / Working Pressure

With the test meter connected and the door of the appliance closed, check the inlet pressure is correct.

Light the appliance referring to the lighting instructions. Run the appliance on a full rate and check the working pressure is correct.

Turn off appliance and allow it to cool, remove the test meter.

Burner Pressure

Connect a suitable test meter to the burner pressure test point.

Light the appliance referring to the lighting instructions. Run the appliance on a full rate and check the burner pressure is correct.

Turn off appliance and allow it to cool, remove the test meter.

9. Placement of Logs & Embers

Logs and embers are only available from Chesneys stockists.

Important Notes:

The placement of fibre logs and embers must be installed in accordance with these instructions; any deviation may cause poor combustion.

If any of the components are broken **DO NOT INSTALL**.

Do not to add more fibre logs onto the fire bed than specified.

Please be cautious when applying glow strands in and around the pilot assembly, as this can lead to ignition problems causing the appliance to enter error status. Visuals of the pilot assembly must be completed when commissioning or servicing the appliance.

Fitting the log base for the Standard and Large Gas Stove Conventional Flue and Balanced Flue V1

Embers / Glow Strands

Please keep glow strands from around the pilot area as this will lead to “arcing” and a malfunction of the pilot assembly. Only the large embers provided are to be used, please dispose of any other embers provided.

Pour the embers in to the burner tray and spread the embers evenly across the tray bed.

The embers provided are to be placed in a single layer on the top of the burner bed, any remaining embers should be kept as spares. Place some of the glow strands over the embers.

Fig.27



Fitting the log set for the Standard Gas Only the large embers provided are to be used, please dispose of any other embers provided.

Fig.28



Place log 3 at the rear of the stove with the back of the log resting against the rear of the chamber. The bottom left and right corners of the log should rest on the grate with the centre of the log elevated.



Log 4 sits with the right corner of the log resting between the log guard and the right hand stainless steel panel. The rear of the left hand side of the log rests against log 3.



Log 1 is placed across the front of the burner with the rectangular piece towards the left of the stove touching the stainless steel panel.



The bottom of log 2 rests against the log guard, the top part of the log rests on log 4.

Fitting the log set for the Large Gas Stove Conventional Flue and Balanced Flue V1

Fit the log set according to the following set of photos.

Fig.29

Log 5 is to be placed at the rear of the chamber. It rests on the burner bed and against the rear of the chamber.



The bottom of log 10 rests against the log guard and against the right hand corner of the stove, with the top log resting on the centre of log 5.



The top part of log 6 has a protruding knuckle that slots into the recess channel of log 10. The bottom of the log rests against the log guard and the front left corner of the stove.





The bottom of log 8 rests against the log guard, the middle of the log rests on log 6.



The bottom of log 9 rests on the burner bed, with the top of the log resting on log 10.



The bottom left corner of log 7 rests on the burner bed and against the log guard. The top of the log rests on log 6.

Fitting the log set for the Large Gas Stove Conventional Flue and Balanced Flue V2.

Fit the log set according to the following details.

Fig. 30b

Log Identification

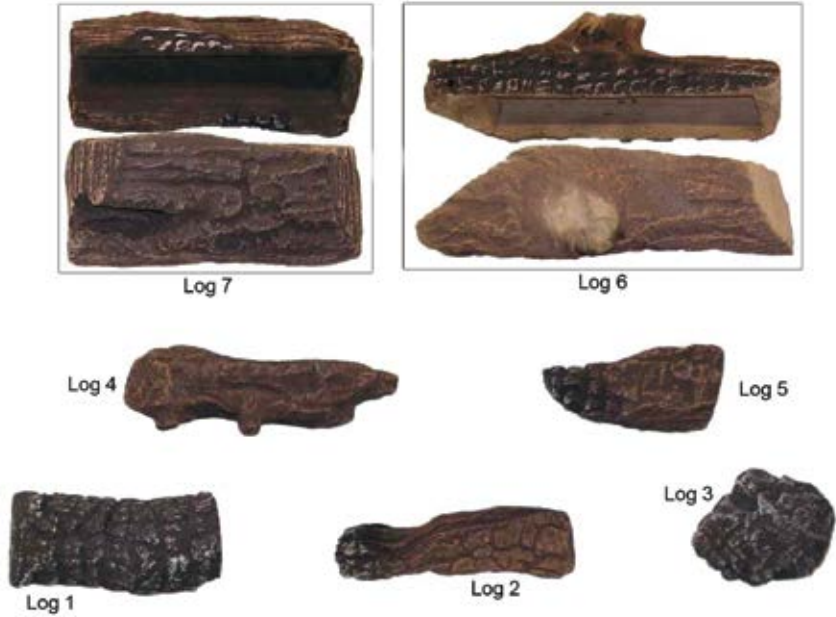

Scatter Embers and Glow Strands as detailed above. Fit Log 1, centrally under Log Burners and behind the Primary burner.

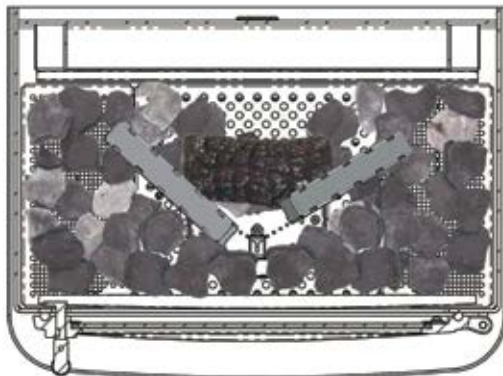

Fit Log 2 in front of the Primary burner and positioned to the Right centre of the appliance.



Fit Log 3 under the Right Hand Log Burner, to the Right of the Primary burner and behind Log 2.



Fit Log 4 diagonally from the Left Hand Log burner and resting on top of Log 1.



Fit Log 5 to the front of the Primary burner, to the Left of Log 2, lying diagonally, parallel to the left Hand Log Burner on Log 4.



Fit Log 6, one of the Logs with a slot under, on top of the Right Hand Log Burner sitting in the Slot.



Fit Log 7, the other Log with a slot under, on top of the Left Hand Log Burner, the Log Burner sitting in the Slot.



The Log arrangement is now complete, make sure the Pilot assembly is left clear and that the Pilot assembly smoothly lights the Primary Burner and that the Primary Burner smoothly ignites both Log Burners.

10. Commissioning the Fire Unit

Check the gas supply and gas appliance for soundness.

The appliance must be fully fitted; the door of the appliance must be sealed.

Check that there is no movement of the door or gaps in the seal.

Check that all the products of combustion are entering the flue and that no products of combustion are entering the building.

Lighting the appliance for the first time

IMPORTANT NOTE - Do not run the appliance with the door open, or damaged.

When lighting the appliance for the first time, the materials (i.e. paint, sealants etc.) will give off smoke and an unpleasant odour. This is quite normal and will disappear after a few hours. During this period, keep the room well ventilated.

Check that all available functions work correctly (See 'Lighting the appliance' in User Instructions for information).

Light the fire on maximum and run for at least 30mins or until the logs start to glow before turning the appliance to low rate.

NOTE – The flames will start off blue until the appliance has heated properly before turning more yellow.

Spillage Test

A spillage check must be completed. The spillage test is intended to check the draw in the chimney. Close all doors and windows of the room in which the appliance has been installed. Testing is to be done with the appliance on 'high' rate and has been running for at least 10 minutes. Check the appliance for spillage using a smoke match and correct test equipment place a lit smoke match just inside of the draught diverter opening at the rear of the appliance.

Fig.30

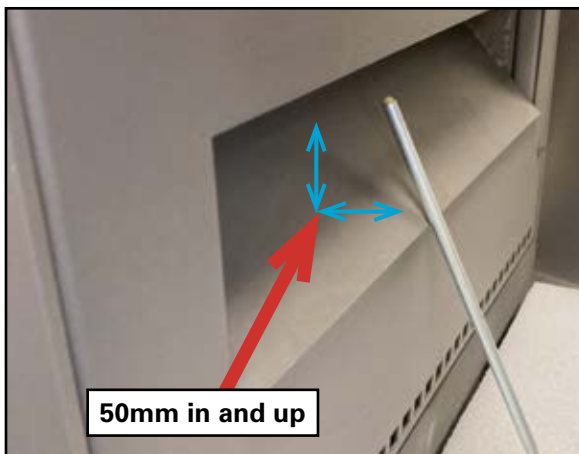

If the appliance and chimney is functioning correctly all smoke will be drawn into the air intake and out of the room. If the smoke does not get drawn into the appliance, allow the appliance to run on maximum rate for a further 10 minutes and repeat the test. If the smoke continues to spill then the unit is to be disconnected and expert advice taken.

Spillage test for balanced flue (room sealed) models

The balanced flue gas stoves are classified as room sealed appliances and therefore require the door of the stove to be locked by the installation engineer following satisfactory smoke/CO room test and completion of the commissioning.

Flame stability

IMPORTANT NOTE -The appliance should always be observed when lighting. On starting the appliance the ignition will light the pilot, once established the main valve opens to 'High rate' to allow gas through to the main burner. All of the main burner should light within 6 seconds lighting the whole burner area.

If this does not happen then the appliance should be turned off allowing 5 minutes before attempting to relight.

Check the stability of the flame by turning to low rate then back to high rate then to low rate doing this around three times whilst observing the stability of the main burner and pilot flame, there should be no problems lighting the main burner.

Pressure Check

The appliance has been adjusted to give the correct heat inputs as listed in the technical details. No further adjustment is necessary. Always check the inlet pressure and burner pressure.

1. Turn off the gas valve on the appliance.
2. Release the screw on the Inlet Pressure test point on the gas valve and connect a manometer.
3. Check that the measured pressure is as the prescribed supply pressure.
4. Perform the test when the appliance is burning on full.
5. If the pressure is low, check the gas supply pipes are correct sized.
6. If the pressure is too high (more than 5mbar over) the appliance may be installed, but the gas supply company should be contacted.
7. Release the screw on the Burner Pressure test point on the burner assembly and connect a manometer.
8. Check that the measured pressure is as detailed in the Technical details.
9. The measured value should be within +/- 10% of the described value. If this is not the case, please contact the supplier.

Note: After checking the pressures and removing the manometers, the screws in the Pressure Test points must be closed, and the system must be checked for gas-tightness.

Aeration

IMPORTANT NOTE –The appliance aeration is factory set and under NO circumstances be adjusted by the installer.

As part of the commissioning process the installer is required to fill in commissioning check list in section17 of this manual.

Locking the door balanced flue models only

The door needs to be locked using the C spanner by tightening the locking ring located on the door handle mechanism.

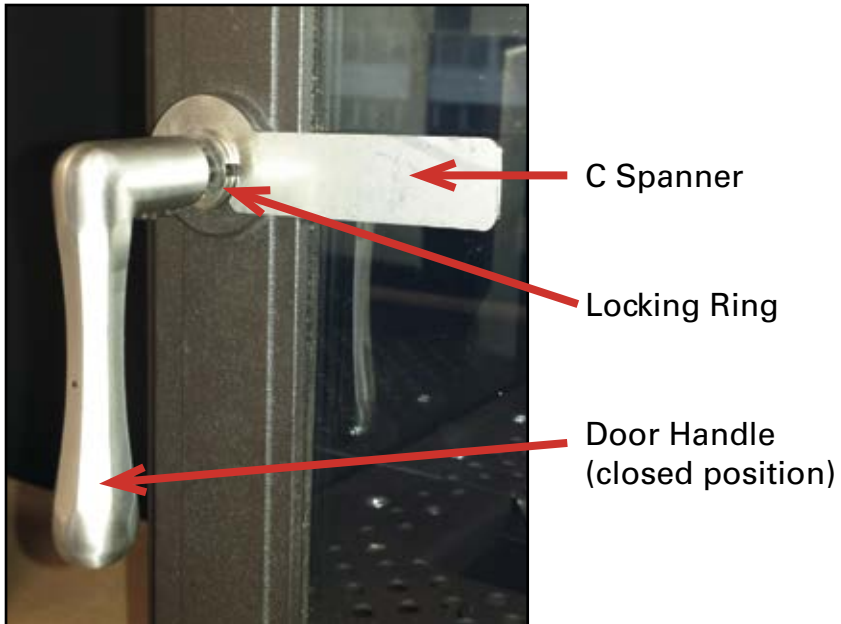

11. Briefing & Handover to the Customer

Instruct the customer on the full operation of the appliance.

For balanced flue models inform the customer that the stove is a room sealed appliance that requires the door to be locked at all times. The door is an integral part of the combustion chamber and can only be accessed/opened by a qualified and registered gas engineer.

Warn the customer that the fire unit may give off a temporary odour; this is normal running in of the unit, and will disappear after a short period of use.

Inform the user that the appliance glass is only to be opened when servicing, and not to disturb the fibre logs as this may disturb the combustion.

Inform the customer that it is recommended that a full service on the appliance and flue checks be carried out annually by competent person/s.

Caution - Make the user aware of the location of the isolation valve and tell the user to close the isolation immediately in case of malfunction / bad performance and to contact the installer in order to prevent dangerous situations.

Instruct the user that the pilot light and flame sensing device fitted to this appliance is also an atmospheric sensing device, designed to shut off the appliance if the evacuation of products of combustion is disturbed. If the appliance repeatedly shuts off after being re-started (as detailed in the 'Lighting instructions' section), a GAS SAFE registered engineer should be contacted to examine the appliance and installation.

Inform the user to always observe the appliance when lighting, once the pilot is lit the main valve then opens to 'High rate' allowing gas through to the main burner. The main burner should then light within 6 seconds **if this does not happen then the appliance should be turned off allowing 5 minutes before attempting to relight.**

Warn the user of the following points:

- not to block vents and to check regularly and remove any blockages.
- not to block the air intake on the appliance.
- that all parts of the appliance will become hot while the appliance is running, so it is recommended that a guard conforming to BS8423: 2002 be used for the protection of young children, aged or infirm persons.
- not to stand too close to the appliance for prolonged periods of time; loose clothing is particularly at risk of burning, and that rubbish cannot be burned in the unit.
- against placing combustible material directly in front of the appliance. Floor coverings such as carpets, are considered to be acceptable.

The stainless steel sides will patinate (mellow) over a period of time this can be cleaned with a hob type cleaner if a high reflection is preferred.

Ensure the installer details are filled in.

Hand over the installation manual to the customer.

12. Servicing & Maintenance

It is advised that the appliance is serviced annually by a qualified person to Local and National Regulations.

Only carry out maintenance work when the appliance is cold.

Exchangeable Components List

Common Parts:

Pilot unit

Injectors

Multi-functional control gas valve: Thermo Electric Safety Control (TESC01)

Logs Embers Door seal

Interior reflective panels

Annual Maintenance

Safety precautions must be taken when cleaning the appliance.

Ensure the appliance is cold before carrying out a service.

Isolate the appliance and disconnect the unit.

Always test for gas soundness and spillage after refitting the appliance.

Check all logs, pilot burner/ignition unit, for soot or debris deposits.

Replace all misplaced logs and retest.

On the failure of pilot burner/ignition or control valve, have the repairs carried out by a competent person.

The door seal should be visually checked during services, if it is deteriorated/split a soundness test should be completed and the seal replaced if the seal is found to be spilling.

Changing the batteries

The batteries can be replaced by accessing the TESC valve via the stove door, on the standard gas stove models the access panel above the plinth can be removed. This panel must be replaced after replacing the batteries.

Suggested Service Procedure

Turn the appliance OFF and isolate the gas supply. Ensure the appliance is fully cold before attempting to start servicing the appliance. No liability can be accepted by Chesneys for injury caused by burning or scolding by a hot appliance. A suggested procedure for servicing is listed below:

- Protect all floor coverings.
- Open front door assembly.
- Carefully remove the Ceramic components (including embers) or gravel.
- Use a vacuum cleaner to clean the top of the burners and grate.
- Remove grate.
- The pilot is clearly visible at the front of the burner. Use the vacuum cleaner and a soft brush to clean the pilot assembly. Never modify or bend the thermocouple.
- Turn on the gas supply and check for leaks, check the burners and pilot for good condition and operation.
- Replace grate embers and ceramic logs.
- Close and lock door and check door seal.
- Check the flue system and terminal, making sure that the terminal vent is fully clear.
- Light the appliance and test setting pressures.
- Check the safe operation of the appliance.

Inspecting the Flue / Chimney

The appliance must be serviced by a qualified person in accordance with local and national regulations.

An inspection of the flue / chimney must be carried out on an annual basis or if the appliance is suspected that it is not expelling the emissions correctly. Check the effectiveness of the flue by carrying out a spillage check.

If the appliance fails, a further inspection of the flue must be carried out.

NOTE – To access the flue/chimney the appliance must be isolated.

Remove any debris such as soot, masonry etc. If there are excessive amounts of debris the register plate must be accessed through or be removed to clean the void area. On completion of the servicing/maintenance a spillage test must be carried out once the appliance has been fully reinstalled.

Replacing the Glass Seal

The stove door seal is a perishable item and should be visually checked during services, if it is deteriorated/split a soundness test should be completed and the seal replaced if the seal is found to be spilling.

If the glass seal is cracked and starting to leak emissions then it must be replaced. The seal is available from most Chesneys suppliers.

Observe the old seal placement before removing. Remove all the old seal and clean off any dirt and old adhesive. Start from the bottom centre of the door carefully adhere the seal around the edges to ensure a good seal. Follow the instructions provided with the seal in line with this manual.

13. Fault Finding

Symptom	Check List
Unit does not respond.	Check remote is working properly.
	Check battery power supply.
	Check wiring is correct.
	Check main switch is in the on position.
Handset does not work.	Check battery power.
	Check handset is in range (wifi symbol displayed on handset).
	Ensure the handset is paired.
Unit starts but no spark or weak spark.	Check spark lead is connected properly.
	Check spark electrode is in the correct area and the gap correctly distanced.
	Check spark lead is not arcing on other parts of the appliance
Unit sparks but does not light pilot.	Check for a good spark.
	Check the spark is in the correct area.
	Check if the ventilation is not too strong.
	Check if there is gas running through.
If there is no gas.	Check isolation tap/shut off valves are free from grease.
	Check isolation tap/shut off valve/s are on.
	Check for blockages.
If there is gas but pilot does not light.	Check pressure is correct.
	Check for blockages.
	Check for draughts.
	Check the pilot gas slots are clear.
	Check for a clear spark.
Pilot lights but does not light main burner.	Check the pilot flame is heating the thermocouple.
	Check ventilation is not too strong.
	Check ventilation is not too strong and the flame is not blowing off the thermocouple and flame rectification probe.
	Check gas pressure is correct.
	Check pilot and burner flame stability.
Burner lights but turns off within a short period.	Check ventilation is not too strong and the flame is not blowing off the thermocouple and flame rectification probe.
	Check gas pressure is correct.
	Check pilot and burner flame stability.

TESC CONTROL FAULT CODES			
FAULT CODE	DESCRIPTION OF FAULT	POSSIBLE CAUSE	ACTION TO TAKE
E00	TESC has failed all automatic ignition attempts.	No gas available or air in pipework. Pilot pipe/injector blocked. Pilot aeration blocked. Insufficient gas pressure. Break in the ignition cable. Thermocouple aged or damaged. Flame is not covering the spark electrode.	Check gas supply. Check for blockages. Clear aeration hole. Check gas supply. Check ignition cable. Replace pilot assembly. Ensure correct gap.
E01	Low current from thermocouple or CO alarm.	Unstable pilot flame from draughts. CO is too high in ambient atmosphere. Defective thermocouple.	Investigate draught issue. Investigate CO release. Replace pilot assembly.
E02	Too high ambient temperature around the TESC control.	Faulty installation of fire. Problems with down draught in the flue. Incorrectly located ceramics.	Allow appliance to cool before relighting.
E03	Thermocouple not connected or bad connection.	No thermocouple connected Incorrect connection/ reversed. Defective, damaged or worn thermocouple.	Check all connections and rectify. Replace pilot assembly.
E04	Flame detected on pilot after burner shutdown.	Carbon contamination on the spark electrode.	Clean the spark electrode.
E05	Flame detected on pilot before burner starts.	Carbon contamination on the spark electrode.	Clean the spark electrode.
E06	Too low voltage on power supply to start the burner.	Flat batteries. Damaged battery contacts. On/Off switch contact issue in valve.	Replace the batteries in TESC. Clean contacts. Operate switch to clean contacts.
E14-E17	Issue with valve buttons.	Buttons are sticking. Buttons are damaged.	Release buttons. Replace valve.

FAULT CODE	DESCRIPTION OF FAULT	POSSIBLE CAUSE	ACTION TO TAKE
E24	Thermocouple not reached temperature within 1 minute.	Aged or damaged thermocouple or wire insulation damaged. Blocked/contaminated pilot.	Replace pilot assembly. Clear blockage or contaminant.
E32, E46, E47, E53, E53- E56	Self-calibration procedure of the valve fails.	Flat batteries Liquid inside electronics (leak detection fluid).	Replace batteries. Replace valve.
E33-E39, E40-E42	Internal piston is having trouble moving.	Contamination in valve inlet/outlets with debris from supply pipe or jointing compounds. Mechanical damage to valve.	Clear contamination, reset allow to cool down before restarting. Replace valve.
E48	Thermocouple short circuit.	Connection reversed. Insulation damaged-shorting to chassis. Defective, damaged	Rectify connection. Replace pilot assembly. Replace pilot assembly.
E49	Control sensing a false flame signal on the electrode.	Contamination of electrode-carbon deposit or conductive liquids (leak detection fluid). Contamination at rear of valve where ignition cable and thermocouple connections (leak detection fluid).	Clean electrode/ replace pilot assembly. Clean contacts/ replace damaged pilot assembly or valve.

Important note for the TESC control system:

To reset any error code the power button on the handset/valve will need to be pressed. False error codes can be displayed if the batteries are faulty or lack enough power to operate the valve.

14. User Instructions

General

The flue must be fitted in accordance with Local and National Regulations.

The flue must not be shared with any other appliance.

It is advised that flue specialist inspect the flue system on an annual basis to ensure that the flue system is sound and the combustion products outlet (terminal) is clear of obstruction.

It is highly recommended that a full service on the appliance be carried out annually by competent person/s.

The gas connection must be in accordance with Local and National Regulations.

Installation and servicing must be carried out by a competent person in line with relevant regulations.

We highly recommend that your fire is turned on at least once a month (for 10 minutes) even during the summer months. This will ensure that the appliance is in good working order. Please check battery levels in both the handset and fire and replace as required.

Chesneys recommend the fitting of a Carbon Monoxide detector that conforms to EN 50291 where ever a gas appliance is installed.

WARNING: Do not operate the appliance if the glass is broken, or door is open.

Do not to block the air intake on the appliance.

Do not make changes to the appliance.

IMPORTANT: Fireguards

Due to the nature of the appliance, all parts of the appliance will become hot during normal operation, so it is recommended that in the presence of young children (i.e. in nurseries) the elderly or infirm persons a guard conforming to BS 8423 shall be used.

Do not leave children and persons who cannot judge the consequences of their actions alone with a burning appliance and place the remote control out of reach.

Allow adequate clearances for curtains, pictures, soft furnishings, electrical appliances or any items that may get damaged through heat.

WARNING: Curtains should not be positioned above the appliance.

Chesneys advise a minimum clearance of 500mm around the appliance for curtains with an additional allowance being made for curtain movement so that the 500mm perimeter is not compromised. The use of curtain tie backs may be considered as a suitable means to limit curtain movement.

It is also advised against placing combustible materials or soft furnishings directly in front of the appliance.

Blown vinyl wall paper or coverings must not be used on the chimney breast where the appliance is fitted.

All parts of the appliance become hot while running and should therefore be considered to be a working surface.

It is also advised against placing combustible materials or soft furnishings directly in front or above the appliance. Floor coverings, such as carpets (up to the hearth), are considered to be acceptable.

Do not disturb the fuel bed. Debris from any source, or soot formed, should be removed from time to time.

The pilot light and flame sensing device fitted to this appliance is also an atmospheric sensing device, designed to shut off the appliance if the evacuation of products of combustion is disturbed. If the appliance repeatedly shuts off after being re-started (as detailed in the 'Lighting instructions' section), a GAS SAFE registered engineer should be contacted to examine the appliance and installation.

Ventilation – GB appliances under 7kW (net) do not require permanent ventilation in accordance with BS 5440-2.

NOTE - Other countries may vary ensure ventilation requirements are in accordance with national regulations.

The appliance when lit from cold will start off with a blue flame and will gradually turn more yellow as the flue, logs and appliance heat up.

Important Notes:

- For balanced flue models the door forms an integral part of the combustion chamber and can only be accessed/opened by a qualified and registered gas engineer. The balanced flue gas stove is a room sealed appliance that requires the door to be locked at all times. The appliance must only be opened for maintenance by a suitably qualified and registered engineer.
- The appliance must not be operated if the appliance door is open, broken or has been removed.
- The appliance should always be observed when lighting.
- Improper installation, service, maintenance, adjustment or alterations may cause injury or property damage.

- Do not disturb, add extra fibre logs or embers as this will affect combustion.
- Do not operate the appliance if the fibre logs are damaged.
- The appliance must be installed and maintained by a suitably qualified and registered engineer.
- Ensure this manual remains with the appliance.

Cleaning

Cleaning should only be carried out when the fire is turned off and cold.

This appliance contains no asbestos.

Cleaning Paintwork

Use a clean soft dry brush or a vacuum to remove dirt and debris from the appliance.
DO NOT USE ANY CHEMICALS OR OILS TO CLEAN THE APPLIANCE.

Cleaning Glass

The glass is specially formulated to withstand very high temperatures use a mild glass cleaner. Use a soft cloth to avoid scratches that may weaken the glass.

Important Notes:

- Ensure the appliance is cold.
- Ensure the glass is clean on both sides as dirt; oils etcetera can etch the glass.
- Do not clean with abrasive materials as this can accelerate dirt accumulation and weaken the glass.
- Ensure the door is fitted correctly to avoid spillage.
- Check spillage after carrying out work.

The glass may collect a white powdery residue on the inside of the glass this is a combination of minerals and acids in the gas.

It is known the longer left on the glass the harder it is to remove.

Cleaning the Stainless Steel panels

The Stainless Steel sides will patinate (mellow) over a period of time this can be cleaned with a hob type cleaner if a high reflection is preferred.

Fuel Bed Components

Wear suitable safety equipment when cleaning the products inside the appliance. It is advised to wear protective gloves and a dust mask conforming to EN 149:2001+A1:2009 FFP3 (available from most DIY shops) when cleaning the logs and embers.

It is necessary to clean the fire if debris or soot deposits have accumulated on the logs. A soft brush is advised to clean the logs and burner unit.

The ceramic parts are fragile; care must to be taken when handling this product.

Warning – Do not change the fuel bed layout or the quantity of material.

When placing the logs it is important to carefully follow the layout in this manual, the layout has been set to give the best performance and flame picture of the appliance any deviation may cause poor combustion.

The addition of further ceramic components are strictly prohibited, any extra parts supplied are spares for future use.

Ceramic components should last around 2 years in normal use at which time is recommended that they are replaced. Replacements can be bought from any Chesneys stockists. State the model number (found on the gas fire data plate). Always ask for genuine Chesneys parts.

This appliance is manufactured by:

Chesneys Limited
194 – 200 Battersea Park Road
London
SW11 4ND
Tel: 020 7627 1410
Fax: 020 7622 1078

15. Control System Information

Control System Information TESC

The appliance is fitted with the Thermo Electric Safety Control (TESC). The system operates on radio frequency and has a remote control handset.

The gas control has an automatic ignition system, therefore does not have a standing pilot.

The control required 3 AA size alkaline batteries to be inserted under the battery compartment cover.

The handset and control device has been paired up and is ready to use.

Fig.31

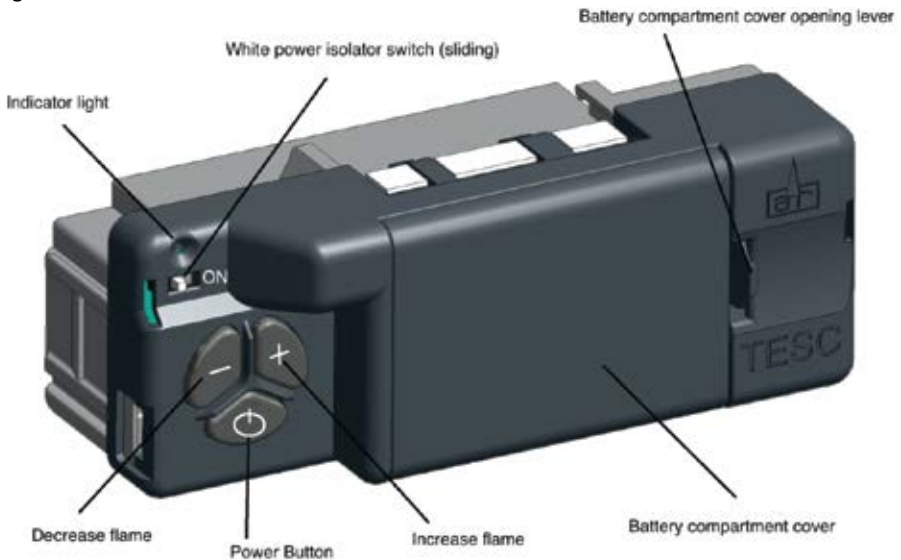

Handset

Ensure the power isolator switch on the front of Fire Control is in the on position I.

NOTE: For safety reasons a button must be pressed and released for the command to be recognized. Keeping hold of a button when pressing (unless otherwise instructed) will not be recognized as a command.

To operate the handset it must be held in your hand so always ensure you have a good grip around the handset to unlock its functions. The green unlock light will illuminate to show when the handset is unlocked and ready to accept commands. This operation must be performed each time you want to operate the handset.

Handset function and display

Fig.32



Lighting the appliance

Important –To operate the handset it must always be unlocked, this is carried out by firmly holding the handset in one hand, which will allow operation of all functions.

Step 1: Unlock the handset by holding it.

The green unlock light will illuminate. Keep the handset held to keep the control unlocked, to enable operation of the buttons.

Step 2: With the other hand press the power button for about 3 seconds until:

A short acoustic beep will be heard and the unlock light on will flash, the word “pilot” will appear at the bottom left hand corner of the display screen. At this point release the power button.

Step 3: The Fire should be lit within a few seconds, if it fails to light then repeat the process.

Adjusting the flame height

Step 1: Unlock the handset by holding it.

Step 2: Press the “+” button to increase the flame height, press the “-” button to decrease the flame height

Turning off appliance

Step 1: Unlock the handset by holding it.

Step 2: Press and release the power button, this will turn off both the main burner and pilot burner.

Restarting the Appliance

If the fire is extinguished or goes out in use, allow 5 minutes before attempting to restart following the lighting sequence.

If the fire shuts itself off repeatedly, do not use the fire, and have the flue and fire checked by a suitably qualified person.

If the appliance is not lighting after 4 ignition attempts, close the gas tap and call the installer.

Close the gas tap in case of malfunctions and/or poor operation and warn the installer.

The appliance is designed to display a fault code on the handset in the event of a functional failure, this can be identified from the fault finding section.

Additional control functions

In addition, the remote control can also be used to set a number of additional functions:

- Time and date
- Temperature display in degrees Celsius or Fahrenheit
- Snooze mode
- Thermostat function

Caution - Although highly improbable, we cannot rule out that your appliance's ignition process can be started unintentionally through other remote controls. For example the remote control of your neighbours' gas heater, but also car keys and garage door openers. The result will be that your appliance will burn when you do not want it to.

Unintended ignition of your appliance could be solved or prevented by turning the ON/OFF switch or closing the gas tap near your appliance. This is the safest precaution if the appliance is not in use for long periods to turn the ON/OFF switch to the OFF position and to close the gas tap near your appliance.

Setting the time

Enter the SETUP menu. Hold the handset to unlock the keypad and keep held throughout the following steps.

Press and hold SET for several seconds. The symbol in the top centre will flash. Press and release the "mode" button several times until the word "SETUP" appears flashing in the top right corner of the display.

Press and release "set" again to enter the "SETUP" menu.

Here you can change the clock from 12 hour or 24 hour format, the day of the week, hour of the day, minute of the day and the display in Celsius or Fahrenheit.

To navigate through the menu "SET" moves to the next parameter and "Mode" move back to the previous parameter. "+" and "-" change the display parameter.

Setting the display for 12 or 24 Hour display:

The H indicates that it is time to set the timer to either 24 hour display or 12 Hour (AM or PM) display. Press the "+" or "-" button on the handset to toggle between the two settings. When you are ready to confirm the setting you want press the "SET" button to progress to setting the day of the week.

Setting the day of the week

Press and release the "+" and "-" buttons until the correct day of the week is shown on the display.

(Mo = Monday, Tu = Tuesday, We = Wednesday, Th = Thursday, Fr = Friday,
Sa = Saturday and Su = Sunday).

Press "SET" to accept the day of the week and to progress to setting the Hour of the day.

Note: Whilst doing this setup pressing "SET" advances to the next display and pressing "MODE" will return you to the previous display setting.

Setting the Hour

Press and release the "+" or "-" button to change the hour to the correct hour and press set to store and to move to setting the minute.

Repeat this for setting the minutes.

Setting the temperature display to Celsius or Fahrenheit.

Press and release the "+" or "-" button to toggle between C and F. When the display shows the desired symbol, press and release the "SET" button to store.

As the important settings above have now been done, press and hold for a few seconds the "SET" button for a few seconds and this will exit the setup menu.

Snooze mode

Snooze mode is a time period you can set which will turn off the fire after a certain time period has elapsed. This function can be utilized during both the manual and thermostatic modes.

The snooze time period can be set before or during manual operation of the fire. Hold the handset to unlock as described previously and press the mode button as many times as necessary until the word MAN and the Zzz symbols are flashing at the top of the display. Press and release the set button and this will put the control into Manual snooze mode.

The default time period for the snooze time period is 1:00 hour. Pressing the set button again will show you the snooze time period remaining. This can be adjusted by pressing the "+" or "-" buttons. The timer period that can be set is from 1 minute to 4:00 hours.

After adjusting the time, press set again to enter the time setting required (or if left for a few seconds this time is now stored and used).

Once this countdown timer has reached zero the fire will turn off.

Thermostatic mode

The handset has within it a thermostat sensor and this can be set so the fire will heat the room to match the temperature set in the handset.

There are 2 temperature types that can be set:

- Day mode temperature that has a sun symbol on the display
- the default temperature is 24 degrees Celsius.
- Night temperature that has a half moon symbol on the display
- the default temperature setting is 18 degrees Celsius.

Hold handset and press and release the mode button several times as necessary until the display has a thermometer symbol flashing at the top of the display. Press the set button to enter this mode.

Press the set button again to see the temperature setting that is set and the mode and on the left of the display is a sun symbol showing it's the day temperature.

If a different set temperature is required, while the display is showing this set temperature press the "+" and "-" buttons to alter the setting. When finished either press set or leave and after a few seconds the new setting will be accepted and the display will return to the time of day screen.

The fire will automatically turn to high or low rate depending on the set temperature. When the set temperature is reached while the fire is in operation, the fire reduces the burner power level each minute until the burner is off. The pilot will remain on for a further 30 minutes and if the set temperature is still too high, the pilot will then also extinguish.

NOTE: If at any time the power button is operated during Thermostat mode, the control will cancel any thermostat operation and return the control to manual mode.

Factory Reset of display handset (to enable handset to be paired again)

To reset a handset to factory conditions to enable it to be paired with a control. Hold the handset to unlock. Press and hold set until handset beeps and release the set button. PROG will be at the top left corner. Press and release the mode button until the word SETUP is flashing in the top right corner. Press and release SET to enter the SETUP menu. Press and release the set button around 9 times until you see CA0 on the display. Press then release the + (or - button) to change the display to CA1 and press and release the SET button again. The word TESC will appear in the window to show that this handset is now reset and ready to pair again.

Pairing the handset (with LCD display)

Ensure that the handset and gas fire control have good batteries.

If the handset is in its factory reset condition, the display will show **7ESC** plus the letter (r) and a number (if not please follow instruction below for restoring handset connection)

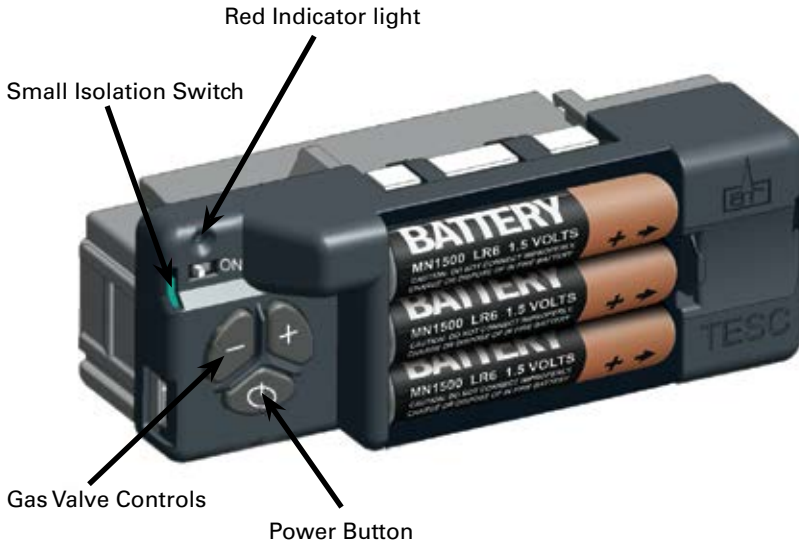

Picking up and holding the handset will unlock the keypad and the green light will illuminate a solid green (and the LCD backlight may come on if the room is dark enough).

Note: Ensure the small isolation slide switch on the top left of the gas fire control is slid to the right position to turn the power on to the valve.

- Place the handset near the fire, i.e. within a metre (3feet). No need to hold the handset at this time.
- Simultaneously press and hold the - and + buttons on the gas valve control (not the handset) until the red light on the top left of fire control begins to flash rapidly, (it will take approx 5 seconds to start flashing), then immediately release the - and + buttons and quickly pressing only the power button on the control.

Note: Pressing of the power button must be done within 1 second of the red light coming on. If not done quickly enough the above process must be repeated until done correctly.

You will then hear an audible sound from the handset and the display will show the symbol " " and the green light on the handset will be flashing. You now have 60 seconds to accept the pairing. To do this pick up and hold the handset and hold it like a handshake to activate the unlocking of the keypad and press and

hold the "SET" button for a few seconds.

- You will hear a few beeps from the handset and the display will enter the setup menu mode.
- Whilst maintaining your grip on the handset, you can now set the display functions of the handset. Momentarily pressing and releasing the SET button advances through the settable features and pressing and releasing the MENU button returns to the previous one. Pressing + or - changes the displayed information, for example:
 - H 24 — This is the 12hr or 24 hr time format. Pressing and releasing + or - will change H24 into H12. Once happy with the setting, press and release SET to move to the day of the week.
 - Day of the week is Mo, Tu, We, Th, Fr, Sa, Su. Again pressing and releasing + or - will change the day and when happy press and release SET to move to the hour of the day. (Pressing Mode button at this stage will return the menu to the previous one, in this case H24/12.)
 - Do the same for the minute of the day and the temperature display C or F.The remaining parameters do not need adjusting so keep pressing the SET button several times to advance the display to the end of the menu.
- You know when the setup has ended as you will see the communication symbol (3 arcs of a circle) in the right hand side of the display. This symbol indicates that the handset is in operation mode (not setup) and in good communication with the fire valve control.

<https://www.youtube.com/watch?v=PWUoPbVMLmw>

IMPORTANT NOTE: Even in the case you do not complete all of the setup, the pairing is still stored once accepted by pressing SET the first time. The handset will re-enter next unlock (pick up) or by entering another setup mode manually. Do not send pairing request again from the valve! If this is done then another factory reset and pairing of the handset is required to be done again.

Restoring handset Connection / Factory Reset

If the handset has lost communication with the Gas Control valve, when the handset is held like a firm handshake the green light will be permanently lit but will pulse brighter. In addition, the communication symbol and other symbols will be missing from the display, and it will appear as shown.



Reset the handset to factory settings to clear the old pairing and enable it to accept a new pairing:

- Once new batteries are inserted, hold the handset to unlock the keypad, and keep hold of the handset while completing the following.

- Press and hold the set button and keep held for around 3 seconds until you hear a second beep. Release the set button once PROG has appeared top left of the handset and SETUP top right.
- When SETUP is flashing, press and release the SET button to enter the menu. You will then see H24 or H12 flashing. Press and release the SET button 9 more times until the display shows CA0. Press and release the + or - button once to adjust the CA0 to a CA1. Then press and release the SET button once again. The display will now revert to factory settings '7ESCr4'.
- The handset is now at the factory reset screen and a new pairing can be performed, refer to see pairing section.
- Please see video link below for further guidance.

<https://www.youtube.com/watch?v=-bbeSuk0IWl>



Press and hold
the set button

Batteries

- What should you do?
- Replacing the batteries at least every 12 months will help prevent damage to the valve and handset.
- Use only brand-new high quality alkaline batteries.
- Always replace the complete set of batteries and do not mix brands.
- Keep contacts clean and do not bend.
- Remove batteries if the appliance is not used for long periods of time. (Prevents batteries from leaking and damaging contacts).
- Do not operate the appliance without the battery covers in place.
- If the handset is dropped or damaged, a replacement maybe required.

How do you know when to replace the batteries?

- Replace the batteries at least every 12 months or during an annual service of the appliance.
- If your handset display shows less than the full battery symbol on the display.
- If the red-light indicator on the gas control valve is flashing every 10 seconds.

What happens if the batteries are not replaced?

- The appliance will stop working or may work intermittently.
- The handset or valve may display error codes.
- The batteries may leak and cause permanent damage to the electronics.
(Replacement components maybe required, which are not covered by warranty).

How to replace the batteries.

The control consists of a handset and the gas control valve within the appliance. There are batteries in both the handset (x2 AA Alkaline) and in the gas control valve (x3 AA Alkaline). The battery covers can be opened by using your finder and pressing down to unhook the clip that retains cover.

Battery Indicator Display

The display switches between FC and RC (FC is the battery inside the Gas Control valve and RC is the battery inside the Remote-Control handset).



If you have the battery symbol showing 3 bars in gas control valve (FC), then this would indicate all is ok. This would also apply when showing RC handset battery condition. This would be ok to operate until 1 bar is showing, if in doubt change the batteries.

Note: Pairing is not lost if batteries are dead or removed



If the battery symbol is showing 0 bars for RC or FC, this means the batteries in the remote require changing. If the appliance does not light, it's best to change the batteries to either Duracell or Energizer prior to reverting to any of the fault 'E' codes.

Removing Batteries

Valve



Handset



- When replacing batteries, ensure care is taken not to bend or damage contacts. The batteries should be held in place firm by the contacts.
- There is an importance to ensure the contacts on both handset and valve are clean, dry, and free contamination.
- The batteries should be placed in the correct direction as shown in the above photos.

Leaking Batteries

If damage is caused to either the gas control valve or handset, this is not a fault of the valve or gas appliance. This can be a sign of overheating which can be caused by poor appliance air supply or flat batteries unremoved from electronic devices. In order to prevent this, the batteries should be changed before they are completely empty and, in any case, every 12 months at point of annual service.

We recommend Energizer or Duracell batteries as they have good power storage and claim they are more resistant against leaking.

Valve



Handset



16. Annex A: Balanced Flue Conversion

The balanced flue gas stoves are supplied as a rear exit configuration, the flue spigots and gaskets are packed inside of the fire chamber, which will need to be fitted prior to installation of the appliance.

Rear Exit Configuration

Fig. 33

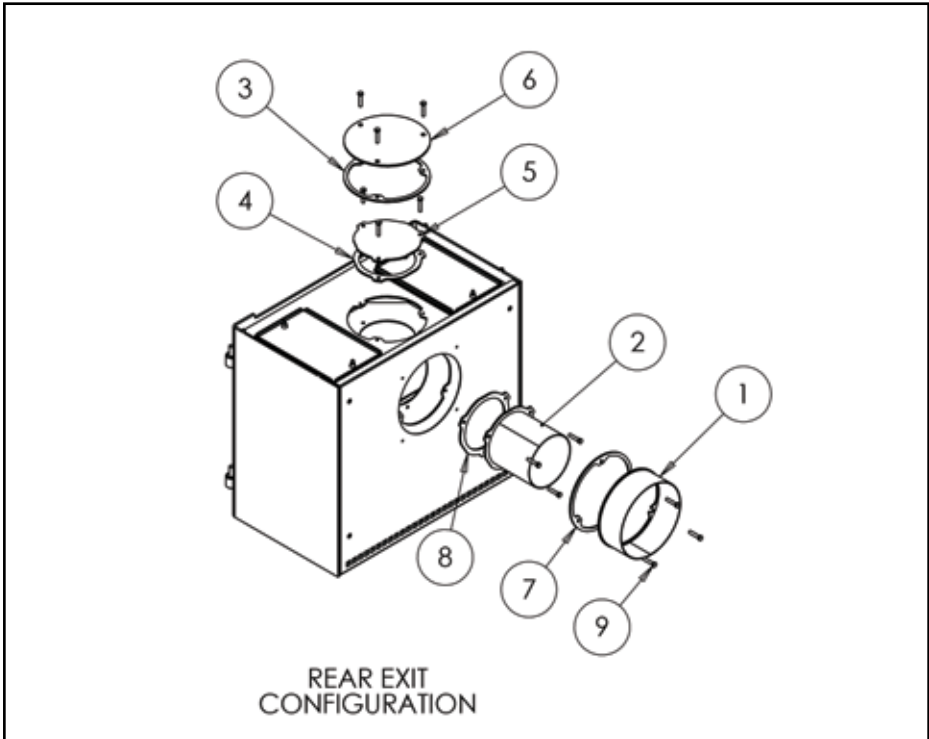

Fitting the flue spigots:

1. The inner and outer flue blank (5 and 6) and gaskets (3 and 4) are factory fitted to the top exits of the appliance.
2. Fit the outer flue spigot (1) and the outer flue gasket (7) to the rear exit outer connection of the appliance using the fixings (9).
3. Fit the inner flue spigot (2) and the inner flue gasket (8) to the rear exit inner connection of the appliance using the fixings (9).

Top Exit Configuration

Only the Large balanced flue gas stove can be configured as a top exit flue configuration.

Stage 1

Fig. 34

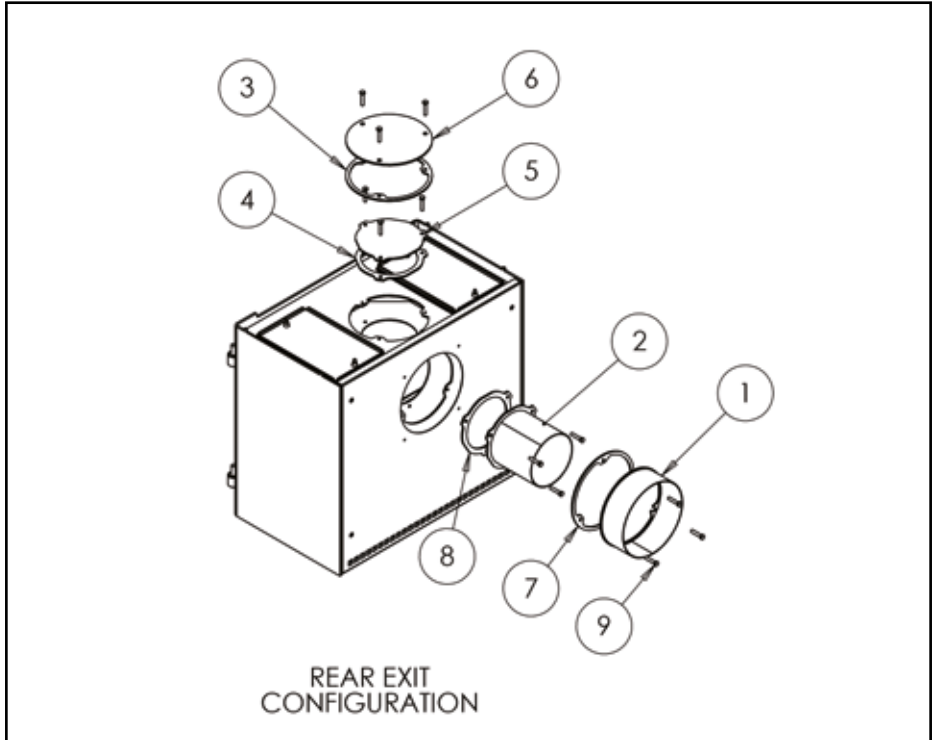

1. Remove the outer flue spigot (1) from the rear exit connection of the appliance.
2. Remove the inner flue spigot (2) from the rear of the appliance.
3. Remove the outer blanking plate (6) from the top exit of the appliance.
4. Remove the inner blanking plate (5) from the top exit of the appliance.

Stage 2

Fig. 35

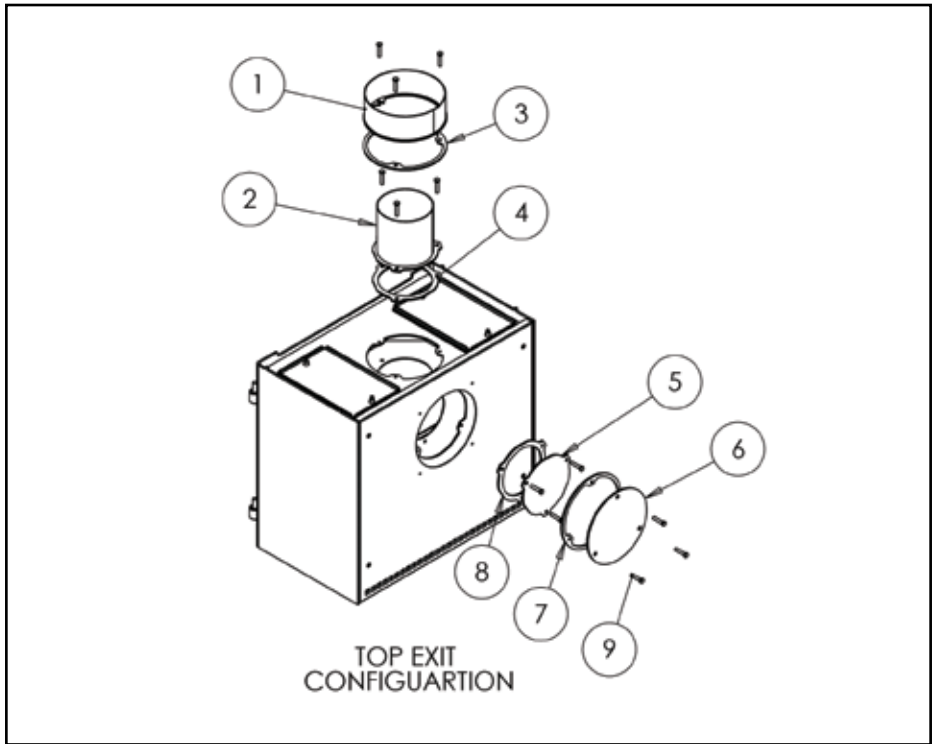

1. Ensure all the gaskets 3,4,7,8 are in good condition, if any are damaged they must be replaced before continuing with the conversion.
2. Fit the inner blank (5) and the inner flue gasket (8) to the inner exit at the rear of the appliance using fixings (9).
3. Fit the outer blank (6) and the outer flue gasket (7) to the outer exit at the rear of the appliance using fixings (9).
4. Fit the inner flue spigot (2) and inner flue gasket (4) to the inner connection at the top of the appliance using fixing (9).
5. Fit the outer flue spigot (1) and outer flue gasket (3) to the outer connection at the top of the appliance using fixing (9).

17. Installer Commissioning Check List

Dealer Name & Address				
Customer Name & Address				
INSTALLER INFORMATION				
Installation Date				
Installer Name				
Address				
Gas Safe Reg No.				
APPLIANCE INFORMATION				
Model Name				
Stove Serial No.				
Burner Serial No.				
Gas Type	Natural Gas		LPG	
Flue Type	Conventional Flue		Balanced Flue	
Flue Diameter				
COMMISSIONING CHECKLIST				
Gas Inlet pressure mbar				
Gas Working pressure mbar				
Gas Rate m3/h				
Flue Flow Test	PASS		FAIL	
Spillage Test	PASS		FAIL	
Ventilation Requirements met	PASS		FAIL	
Approved Carbon Monoxide Detector fitted & tested	PASS		FAIL	
Engineer Signature			Date	/ /

18. Dealer and Installer Information

Dealer
Contact No.
Date of Purchase
Model No.
Stove Serial No.
Burner Serial No.
Gas Type

Installation Company
Gas Safe Registered Engineer
Contact No.
Gas Safe Register No.
Date of Installation

19. Annual Service Record

Annual Service Record Year 1
Gas Safe Registered Engineer:
Contact No.:
Gas Safe Register No.:
Date of Service:
Pilot assembly replaced:

Annual Service Record Year 2
Gas Safe Registered Engineer:
Contact No.:
Gas Safe Register No.:
Date of Service:
Pilot assembly replaced:

Annual Service Record Year 3
Gas Safe Registered Engineer:
Contact No.:
Gas Safe Register No.:
Date of Service:
Pilot assembly replaced:

Annual Service Record Year 4
Gas Safe Registered Engineer:
Contact No.:
Gas Safe Register No.:
Date of Service:
Pilot assembly replaced:

Annual Service Record Year 5
Gas Safe Registered Engineer:
Contact No.:
Gas Safe Register No.:
Date of Service:
Pilot assembly replaced:

Annual Service Record Year 6
Gas Safe Registered Engineer:
Contact No.:
Gas Safe Register No.:
Date of Service:
Pilot assembly replaced:

Annual Service Record Year 7
Gas Safe Registered Engineer:
Contact No.:
Gas Safe Register No.:
Date of Service:
Pilot assembly replaced:

Annual Service Record Year 8
Gas Safe Registered Engineer:
Contact No.:
Gas Safe Register No.:
Date of Service:
Pilot assembly replaced:

20. Chesneys Warranty Information

Warranty/Guarantee Terms:

Your Chesneys gas stove is covered by a standard 1 year manufacturers guarantee. An extended warranty is available, subject to registration. The extended warranty entitles you to a 2 year warranty on the gas valve and a 5 year warranty on the main burner assembly, from the date of installation.

To validate and start your warranty please fill out this form and send it back to:

WARRANTY REGISTRATION
CHESNEYS GROUP LTD
UNITS 12-16 ELDON ROAD,
BEESTON,
NOTTINGHAM,
NG9 6DZ

Alternatively, log on to: <https://chesneys.co.uk/warranty-registration> and complete the online form.

In the event of a breakdown or claim you are required to contact the installer/trade stockist. They will need to investigate the matter and process the claim on your behalf if required.

The extended warranty must be registered within 28 days of installation of the appliance. Failure to register within this time period will result in the guarantee reverting to the standard 1 year from date of installation.

To register you must provide the full serial number of the appliance.

This is clearly shown on the;

- Stove packaging
- Appliance data plate

Please also be advised that your appliance should be serviced annually to honour your warranty. The appliance must be serviced annually by a Gas Safe Registered engineer in accordance with the manufacturer's instructions. Replacement of the pilot assembly is a requirement of the annual service. Failure to do so will invalidate the warranty

Failure to have the stove serviced voids the extended warranty terms.

Service details must be recorded in the Installation and User Manual which must be available for inspection once making a warranty claim.

The cost of annual servicing is not included in the guarantee.

Full terms of conditions can be found at <https://chesneys.co.uk/warranty-registration>



Chesneys Warranty Registration Form

All items are required:

Your Details	
Name	
Address	
Postcode	
Email	

Purchase Details	
Purchased From	
Purchase Date	

Product Details	
Product Name	
Product Colour	
Fuel Type	Gas
Serial Number	

Installation Details	
Installed by	
GAS SAFE registration no.	
Installation date	
Is the flue lined?	YES / NO

