

# CHESNEYS

## **WOOD BURNING STOVES: SOLSTICE 5WS SERIES**

### INSTALLATION & USER MANUAL

**IMPORTANT:**  
PLEASE ENSURE YOU REGISTER FOR YOUR  
APPLIANCE FOR ITS EXTENDED WARRANTY

**[www.chesneys.co.uk](http://www.chesneys.co.uk)**

# CONTENTS

<b>SECTION</b>	<b>PAGES</b>
Safety Information	3
Solstice 5WS Series	4
Technical Information	5
Installation Information	7
Operating the Appliance	15
Maintenance & Care	19
Stockists & Installer Details	22
Commissioning	24
Annual Service Record	29
Guarantee	30
Disposal/Recycling	31
Warranty Registration	32

# 1. SAFETY INFORMATION

- Before installation and/or use of this appliance please read these instructions fully and carefully to ensure that you have fully understood their requirements.
- Please note that it is a legal requirement under England and Wales Building Regulations that the installation of the stove is either carried out under Local Authority Building Control approval or is installed by a Competent Person registered with a Government Approved Competent Persons Scheme.
- All local regulations, including those referring to national and European Standards need to be complied with when installing the appliance.
- Only use for domestic heating in accordance with these operating instructions.
- You must burn only approved fuels. Do not use with liquid fuels or as an incinerator.
- This appliance will become hot whilst in operation. It is recommended that a suitable fireguard in accordance with BS 8423 be used for the protection of children, animals and unauthorised persons.
- Never leave children unsupervised while the appliance is in operation or when it is hot.
- Always use the gloves provided when operating the appliance.
- Do not obstruct inside or outside ventilation required for the safe use of this appliance.
- Do not make unauthorised changes to the appliance.
- Extra fuel should not be stored on or next to the appliance,
- Extractor fans or cooker hoods must not be placed in the same room or space as this can cause the appliance to emit fumes into the room.
- It is a requirement for an electronic carbon monoxide detector conforming to BS EN 50291 to be fitted in the room where the appliance has been installed. This should be maintained and tested in accordance with the manufacturer's instructions.
- This appliance is heavy and must be handled with care.
- Soft furnishing must be at least 1000mm from the appliance.
- This appliance is designed to radiate heat. Do not stand or sit too close to the appliance for prolonged periods of time.
- This appliance is designed to be used with the door shut.
- No aerosols must be used on or in the vicinity of a live or hot stove.

## 2. SOLSTICE 5WS SERIES



Solstice 5WS

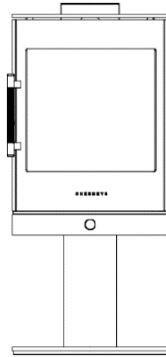

Solstice 5WS PED

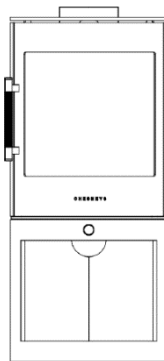

Solstice 5WS LS

### 3. TECHNICAL INFORMATION

Nominal Heat Output	4.8kW
Mean CO emission at 13% O <sub>2</sub>	0.06 vol%
Mean NO <sub>x</sub> emission at 13% O <sub>2</sub>	113mg/m <sub>0</sub> <sup>3</sup>
Mean C <sub>x</sub> H <sub>y</sub> emission at 13% O <sub>2</sub>	24mg/m <sub>0</sub> <sup>3</sup>
Mean Dust emission at 13% O <sub>2</sub>	13mg/m <sub>0</sub> <sup>3</sup>
Mean Flue Gas Temperature	269 °C
Flue Gas Mass Flow	5.3 g/s
Energy Efficiency	75.2%
Test Fuel Size	1.02kg
Fuel: 1x log at <15% moisture	25cm x 7cm
Energy Index	100
Energy Class	A
Seasonal Efficiency	66.2%
<b>DISTANCE TO COMBUSTIBLES</b>	
Rear	100mm
Sides	300mm

DIMENSIONS (mm) & PACKED WEIGHT (kg)						
	A	B	C	D	E	WEIGHT
Solstice 5WS	724	450	225	556	450	113
Solstice 5WS PED	992	450	225	824	450	130
Solstice 5WS LS	992	450	225	824	450	124

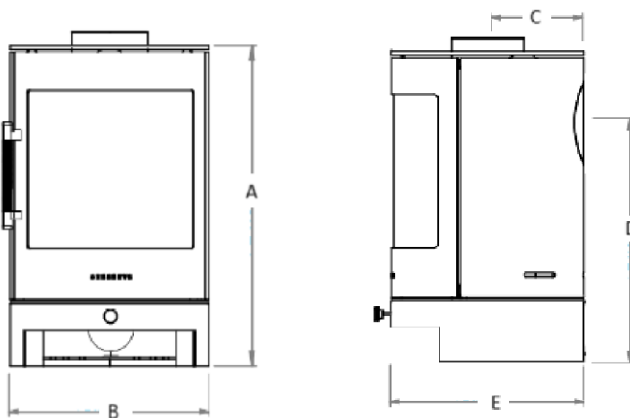

**Distance to Combustibles:**

- For installation at 90° to a wall

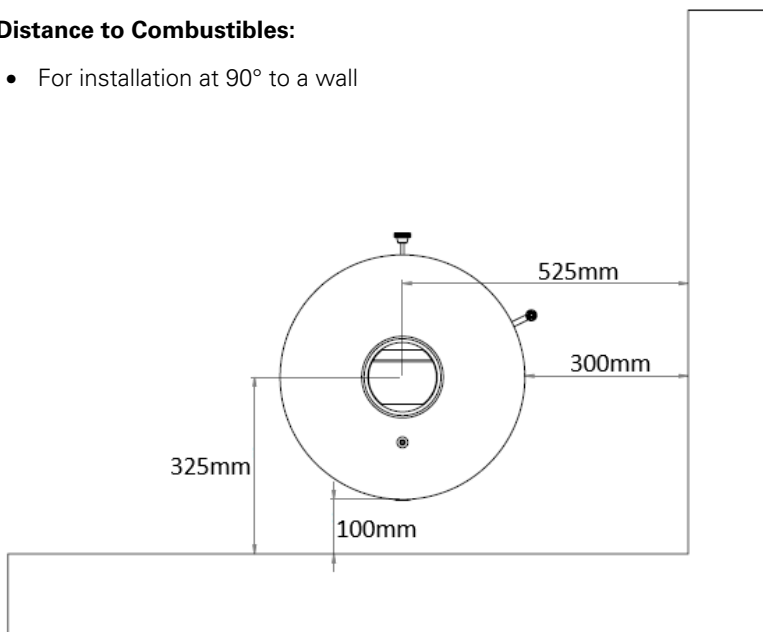

- For installation at 45° to a wall

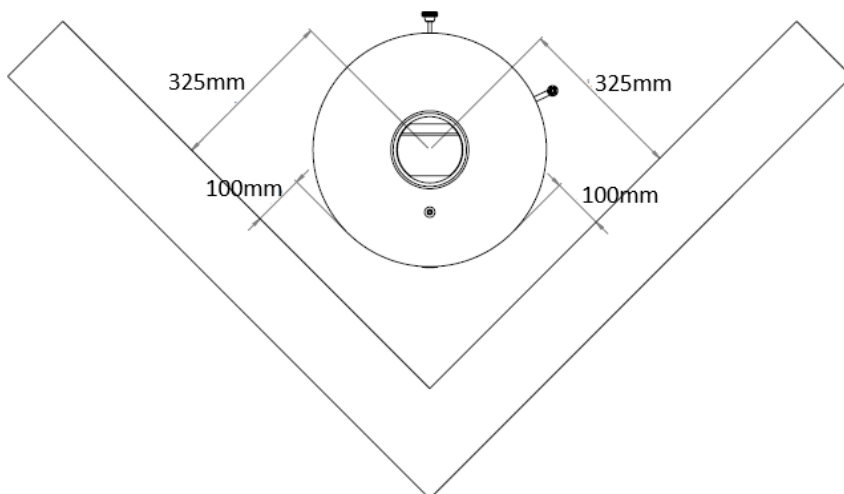

## 4. INSTALLATION INSTRUCTIONS

In addition to these instructions the requirements of BS 8303 and BS EN 15287 must be fulfilled. Local Authority Bylaws and Building Regulations regarding the installation of Solid Fuel burning appliances, flues and chimneys must also be taken into account. The installation is a notifiable building works as defined in the Building Regulations and that it is a legal requirement under England and Wales Building Regulations that the installation is either carried out under Local Authority Building Control approval or is installed by a Competent Person registered with a Government approved Competent Persons Scheme.

Building Regulation Approved Document J for England and Wales Building Regulations Part F for Scotland  
Building Regulations/1997 Technical Guidance Approved Document

J-Heat Producing Appliances for the Republic of Ireland

Registered Body: HETAS (GB only) INFO (Ireland)

This appliance must be fitted by an approved installer or inspected and signed off by a Building Control Officer.

The appliance is supplied fully assembled for a top flue arrangement. A decorative blanking plate is available to purchase should a rear flue be used, please contact the retailer where the stove was purchased.

The lid, door and internal parts can all be removed to reduce the stove weight during installation.

### **Asbestos**

This stove contains no asbestos. If there is a possibility of disturbing any asbestos in the course of installation then please seek specialist guidance and use appropriate protective equipment.

### **Metal Parts**

When installing or servicing this stove care should be taken to avoid the possibility of personal injury.

### **Ventilation**

Please refer to Document J section 2 (table 1). There must be an adequate air supply into the room in which the appliance is installed to allow the appliance to function properly.

The installation of extract ventilation or other appliance that requires air for combustion in the same area are not recommended and will effect this appliance.

Chesneys recommend an appropriate spillage test be conducted with all appliances post installation.

Air inlet grilles must be so positioned that they are not liable to blockage.

## **Hearths**

All Chesneys wood burning stoves can be fitted on a 12mm hearth providing there is sufficient load-bearing capacity.

Chesneys recommend a minimum distance in front of the stove that allows the door to be opened fully and not overhang the hearth. This is a Chesneys recommendations only please refer to Document J Section 2 diagrams 26 & 27.

## **Flue Requirements**

Chesneys stoves must be connected to a suitable chimney.

Chesneys recommend installing a flexible metal liner or insulated twin wall metal chimney system regardless of the condition of the current flue. Due to the exceptional efficiency of these appliances, unlined or non-metal lined flues take a long time to warm up which reduces the effective flue draught and the performance of the appliance.

The inner diameter of the flue spigot is 127mm and a 5" (125mm) connecting flue pipe can be used.

This appliance must not be used in a shared flue system.

During commissioning the minimum achieved flue draught must be 12Pa if measured in the flue or 9Pa if measured using the test point on the appliance with the air control lever fully open.

A minimum flue height of 3m can be used if the minimum flue draught requirements are achieved and a spillage test is successfully completed.

The flue must have a minimum diameter of 5" (125mm).

A 5" (125mm) flue may be used when the stove is fitted in DEFRA mode when fitted in a smoke-controlled area.

Ensure adequate access to cleaning doors is maintained.

If the appliance is fitted in an area that has another flue (mechanical or otherwise) a flue interference test must be completed and recorded. The appliance must be checked with reference to ADJ 1.21, and necessary action taken.

## **Fire Cement**

Some types of fire cement are caustic and should not be allowed to come into contact with the skin. In case of contact wash immediately with plenty of water.



## Converting to Rear Exit

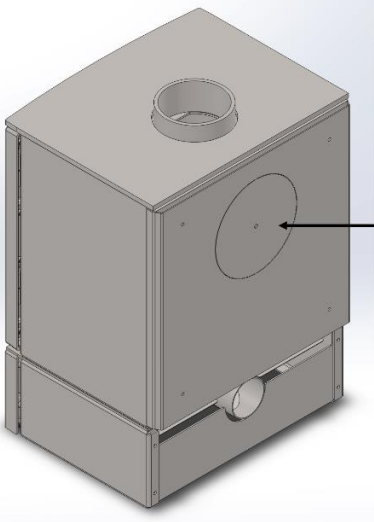

Remove both (2) heat shield covers.

Exposing Blanking plate underneath

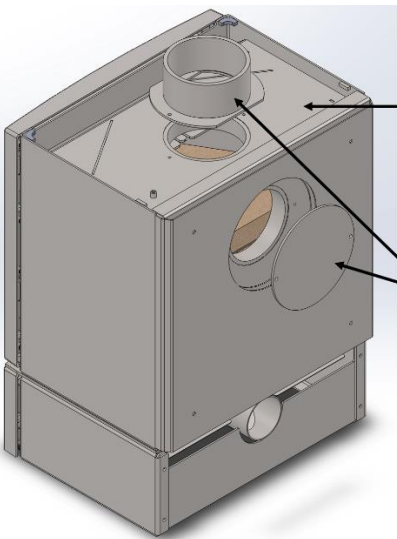
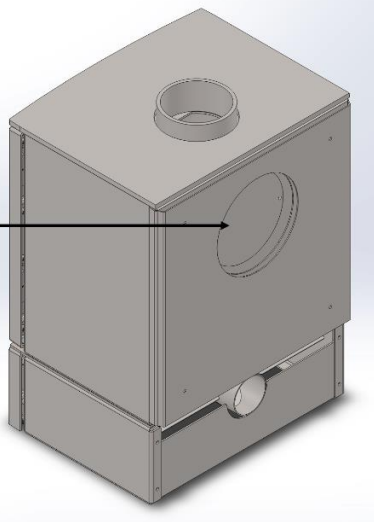

Remove Lid

Unscrew 2x M6 Bolts from Blanking plate & Flue collar.

Switch the blanking plate and the flue over and secure in place with screws.

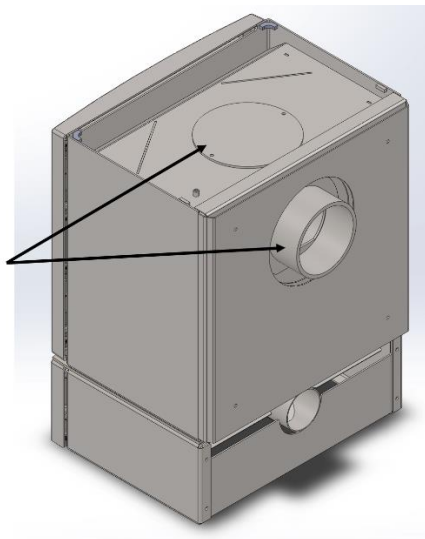

## Flue Draught

The minimum flue draught must be 12 Pascals.

A flue draught calculation could be beneficial before any installation to ascertain if the flue design is suitable to remove the exhaust gases, or at the very least a smoke test is carried out to gauge the effectiveness of the flue.

A flue calculation should be carried out (when coming off the rear of the stove, up to 450mm horizontally) giving the flue design and the total length including bends of the air inlet prior to the installation.

There is an air flow test point located on the top of the stove under the lid, (See image below). This can be used to gain the pascal rating once the stove is installed.

You must carry out a spillage test to confirm the complete system from the air inlet to the flue terminal is working as designed, if the stove fails a spillage test action indicated in the spillage test must be carried out. Do not leave the stove spilling.

You must record the air flow draught and confirm a spillage test has been successfully completed.

The following have an influence on a failed spillage test: Flue design, insulation, cold flue, flue termination, air inlet position, downdraught, atmospheric condition, depressurised room, type and suitability of fuel all are beyond Chesneys control and must be taken into consideration during any flue spillage investigation.

The installer must only use a dedicated external air kit that matches the diameter of the Air Inlet Pipe. This must be installed to meet all the requirements of the manufacturer's instructions, Local Building Regulations requirements and appropriate standards.

## Test Point

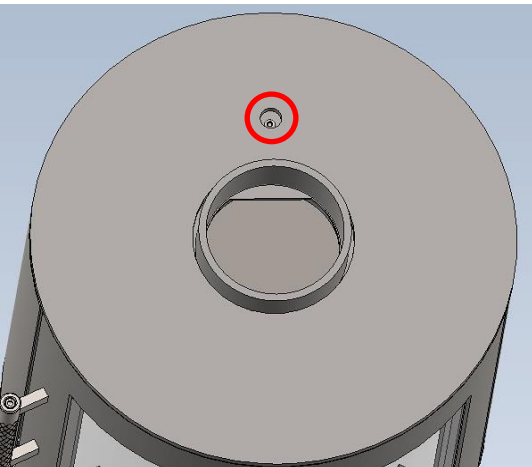

When looking at the front of the stove the air flow test point is located at the rear of the stove behind the flue collar.

Remove the M6 screw to test by using a magnetic tip allen key.

Please ensure the screw is refitted once the test is complete.

## External Air Supply

- There is an Air Inlet Pipe located at the rear of the stove.
- If you are installing an external air supply, position the external air inlet to avoid it becoming blocked with debris.
- The position of the air inlet must take into account atmospheric conditions i.e. prevailing winds.
- This air inlet provides the necessary air for combustion when the door is closed.
- The outer diameter of the Air Inlet Pipe is 59mm. An adaptor will be required to increase to 80mm and can be purchased from your local stockist. The adaptor will extend 62mm beyond the rear of the stove.
- See Diagram and Table below for distance to centre of Air Inlet Pipe.
- **Please note:** the Solstice 5WS PED is not available for installation using an external air supply.



Solstice 5WS	80mm
Solstice 5WS LS	350mm

## **The Clean Air Act 1993 and Smoke Control Areas**

Under the Clean Air Act local authorities may declare the whole or part of the district of the authority to be a smoke control area. It is an offense to emit smoke from a chimney of a building, from a furnace or from any fixed boiler if located in a designate smoke control area. It is also an offence to acquire an “unauthorized fuel” for use within a smoke control area unless it is used in an “exempt” appliance (“exempted” from controls which generally apply in the smoke control area).

In England appliances are exempted by publication on a list by the Secretary of State in accordance with changes made to sections 20 and 21 of the Clean Air Act 1993 by section 15 of the Deregulation Act 2015. Similarly in Scotland appliances are exempted by publication on a list by Scottish Ministers under section 50 of the Regulatory Reform (Scotland) Act 2014.

In Wales and Northern Ireland these are authorized by regulations made by Welsh Ministers and by the Department of the Environment respectively.

Further Information on the requirements of the Clean Air Act can be found here at: <https://www.gov.uk/smoke-control-area-rules>

Your local authority is responsible for implementing the Clean Air Act 1993 including designation and supervision of smoke control areas and you can contact them for details of Clean Air Act requirements.

The Solstice 5WS, Solstice 5WS PED & Solstice 5WS LS have been recommended as suitable for use in smoke control areas when burning wood logs. The appliances above must be fitted with a permanent stop to prevent complete closure of the air control beyond 10mm.

## **Air Controls & Door Left Open**

Operation with the air controls open can cause excess smoke. The appliance must not be operated with air controls, appliance dampers or door left open except as directed in the instructions.

## Installing in DEFRA Smoke Control Areas

- The appliance is exempt from the provisions of section 20 of the Clean Air Act 1993 subject to the following conditions and can be used in Smoke Control Areas in the UK only when the stove is in smoke control mode and is installed in accordance with the current Building Regulations.
- In order to put the stove in to smoke control mode and restrict closure of the Air Flow Bar, the mechanical stop must be fitted.
- There is a bolt provided which is attached to the air flow bar and must be fitted in the position shown in the below diagram on all variants:

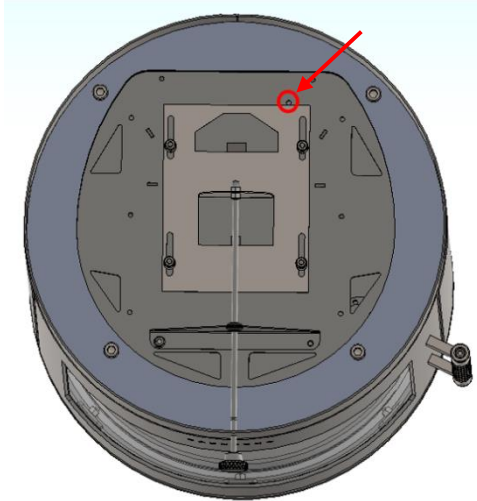

- For the Solstice 5WS you must remove the access panel by removing the 8x M6 screws shown in the below diagram. Once the DEFRA bolt is fitted the access panel must be refitted.

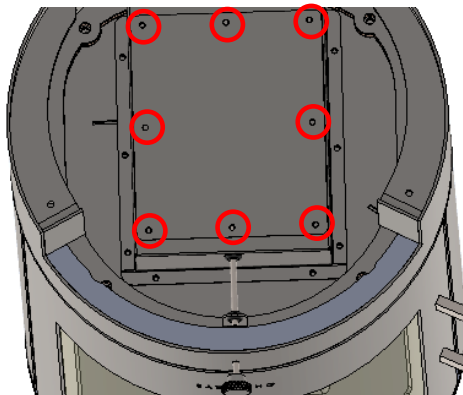

- For the Solstice 5WS PED there is an access point indicated in the below diagram:

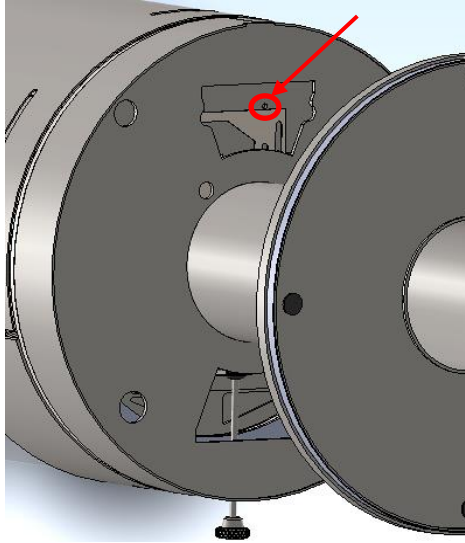

- For the Solstice 5WS LS you must remove the access panel by removing the 8x M6 screws shown in the below diagram. Once the DEFRA bolt is fitted the access panel must be refitted.

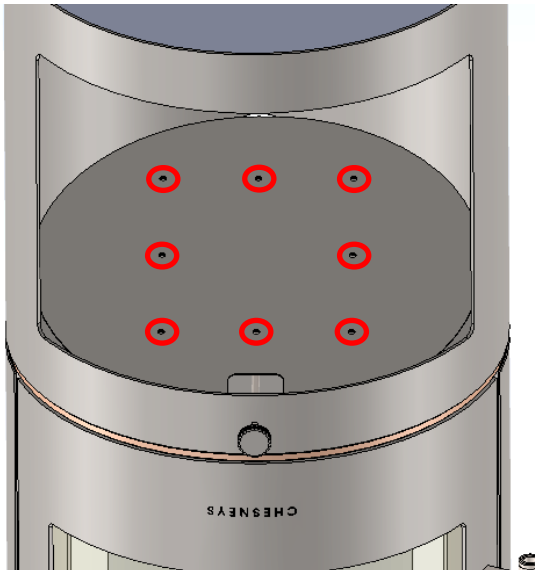

## 5. OPERATING THE APPLIANCE

- Check all internal parts are fitted correctly and there are no gaps between the firebricks and baffles and the log retainer is secure.
- Check the air flow lever is operating freely.
- The internal vermiculite bricks become very brittle when heated and care should be taken not to knock the bricks when loading the fire.
- The better the quality of fuel you use the better the efficiency, controllability and clean burn you will experience.
- Aim to get the stove and chimney up to normal operating temperature as quickly as possible.
- Let the ash build up to 25-35mm deep to help to insulate the bottom fire brick and prolong its longevity.
- Excessive clearing of ash will greatly reduce the lifespan of the floor fire brick.
- Atmospheric conditions do have an effect on your chimney and subsequently the stove. Some of these conditions will cause your stove to “blow back” into the room, or even prove difficult to light. If these symptoms persist please contact your installer, who will be able to advise if your flue arrangement needs to be reviewed or a new specialised cowl installed.
- The appliance is designed to operate with the door closed, except for lighting and reloading, failure to close the door during operation can result in fume spillage.
- Always use the gloves provided when operating the appliance.
- Ensure there is no ash and debris between the door and the body of the stove that could prevent the door from closing and forming a tight seal.

**Warning Note:** Properly installed, operated and maintained this appliance will not emit fumes into the dwelling. Occasional fumes from lighting, de-ashing and re-fuelling may occur. However, persistent fume emission is potentially dangerous and must not be tolerated. If fume emission does persist, the following immediate actions should be taken:

- Open doors and windows to ventilate room then leave the premises. Let the fire out or eject and safely dispose of fuel from the appliance. Check for flue or chimney blockage, and clean if required.
- Do not attempt to relight the fire until the cause of the fume emission has been identified and corrected. If necessary seek expert advice.

Your installer is required by law to fit a CO alarm in the same room as the appliance and in accordance with Building Regulations Document J. If the alarm sounds unexpectedly, follow the instructions above given under “Warning Note.”

## Important Information Regarding First Use

### Curing Process

As with all wood burning stoves your new stove will need to be 'cured' before commencing normal use.

For the first lighting of the stove after installation it is **VERY IMPORTANT** that the door remains slightly ajar. During the first firing the paint finish goes through a curing process which will soften the paint with the heat. As the stove cools down the paint will harden. This process can take several fires and will depend on the temperature achieved and for how long the fire has been left to burn.

Leaving the door slightly ajar during the first firing will prevent the rope from sticking to the softened paint during the curing process.

It is very important to avoid contact with the painted surfaces during the first periods of use while the paint is soft.

Until fully cured the appliance will smoke and emit an unpleasant odour. The odour is non-hazardous however, we recommend keeping the room well-ventilated and if you experience any adverse health effects during use, stop using the appliance immediately, open any windows/doors to allow for fresh air and leave the room the appliance is located.

Operate the appliance at a low output for the first few burns to allow the curing of the materials. Use kindling only on the first two fires which should burn for 15-20 minutes with the second burn being started whilst the appliance is still warm. A full fire should be burnt for 45-60 minutes, again starting while the appliance is still warm, then allowed to cool naturally. Your paint should now have cured and no longer give off fumes or smoke.

Please note that the Parchment paint is more susceptible to marking and soot transference and as a result Chesneys cannot be held responsible for marks made on the stove by the gauntlets or by other means. All paint finishes can be touched up to a factory finish – please see notes on paint application.

### Internal Vermiculite Bricks

The vermiculite bricks are susceptible to moisture and will contain a certain amount on first use. It is important to condition the bricks and dry them out to avoid the bricks splitting by having one or two small fires using a handful of kindling without any logs. The stove should still be cool to the touch, allow the fire to go cold and repeat.

If you see moisture on the inside of the glass when you light your stove this moisture is being absorbed by the bricks and you should slowly build up the temperature of your stove over a 50-minute period.



## **Fuel**

- This appliance is designed and certified for wood burning only.
- It is recommended to only burn logs that carry the Woodsure 'Ready to Burn' logo or with a moisture content of less than 20%.
- Burning wet unseasoned wood will cause heavy tar deposits in the stove, on the glass and within the chimney.
- Burning wet unseasoned wood will result in reduced outputs, lower efficiency and increased emissions.
- The heat output will differ with different types of wood.
- Hard woods (such as Ash, Beech and Oak) are better than soft woods (such as Pine and Spruce).
- The wood should be cut and split, with it left to season in a well-ventilated dry store for at least a year, but preferably two, before use.
- This appliance is not designed to burn household waste.
- The approximate weight of fuel for nominal output operation is 0.96kg.

## **Lighting**

- Light the stove using firelighters, kindling and 2 small split logs.
- Using the top down method, place 2 split logs on the base of the stove and build a jenga-style tower on top of the two split logs with 2 fire lighters on the top.
- Pull out the Air Flow Bar until it is fully extended.
- Light the firelighter and leave the door ajar for a few minutes to assist in starting the fire.
- If condensation appears on the glass when the door is closed, open the door and it should clear in a minute or two.
- Do not leave stove unattended when door is open.
- The side and back bricks will go black when first lit, they will begin to clear after about 20-30 minutes, the fire can be turned down using the Air Flow Bar to the desired setting. Never completely close off the air as this will cause the glass to go black.
- The quality of your fuel and flue draught will influence performance and dictate your setting.

## **Controlling The Fire**

- For ease of use the appliance has been designed with a single control lever. The Air Flow Bar controls the amount of air flowing into the combustion chamber.
- Pull the bar out to allow more air into the chamber to produce more heat and resulting in a faster burn. Push the bar in to decrease the air flow into the chamber thereby reducing the heat produced and resulting in a slower burn.

- There is a groove on the Air Flow Bar to indicate the nominal output level. Move the Air Flow Bar to align with the front face of the base to achieve nominal output.
- If a fire is uncontrollable when the Air Flow Bar is pushed completely in, check the door is securely closed. Allow the stove to cool and perform a paper test.

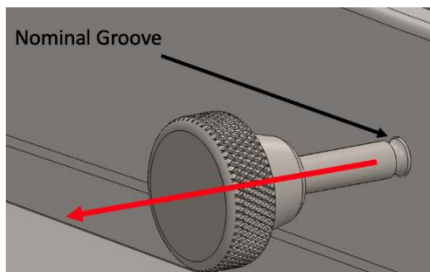

### **Refueling**

- Always try to refuel on a hot bed of ash with plenty of glowing embers.
- Pull the Air Flow Bar fully out and slowly open the door with the glove provided to equalise the pressure inside the stove with the room - if you open the door too quickly ash can be lifted from the chamber into the room.
- Place the wood, bark side down, onto a bed of hot ashes and close the door.
- When the logs have fully turned black set the Air Flow Bar to the desired setting.
- If there are insufficient embers in the fire bed to ignite fresh fuel this can cause excessive smoke - adding suitable kindling can prevent this.

### **Fuel Overloading and Overfiring**

- The maximum amount of fuel specified in this manual should not be exceeded, overloading can cause excess smoke, sub-optimum performance and damage to the appliance.
- In the event of over firing the stove (flue collar, top of stove or log retainer glowing red/ orange) push the air control in fully (with gloves provided) to shut the appliance down.
- Overfiring will damage the stove and is not covered under the warranty.
- Over firing can be caused by: over filling the appliance with fuel, burning on maximum setting for prolonged periods, or with the use of non-recommended fuels.

### **Chimney Fire Action**

- If the chimney is thoroughly and regularly swept, chimney fires are unlikely to occur.
- If a chimney fire does occur push the Air Flow Bar fully in and ensure the door of the stove is securely closed. This should cause the chimney fire to go out.
- If the chimney fire does not go out when the above action is taken then the Emergency Services should be contacted immediately, requesting the Fire and Rescue Services.
- Do not relight the stove until the chimney and flue-ways have been cleaned and examined by a professional.

## 6. MAINTENANCE & CARE

### Essential Annual Maintenance

To maintain the effectiveness and efficiency of your stove it needs to be serviced or inspected annually by a competent person. An annual service is a requirement of our extended warranty.

The installation and flue connection needs to be checked and the chimney swept annually.

If the stove is to be left unused for an extended period, then it should be given a thorough clean to remove ash and unburned fuel residues. To enable a good flow of air through the appliance to reduce condensation and subsequent damage, leave the air controls fully open.

If the stove has not be lit for an extended period, the moisture in the chimney flue will be absorbed by the bricks and they will need to be conditioned as with the Frist Use Instructions. The flue connection, any appliance baffles or throat plates and the chimney should also be swept prior to lighting.

The bricks should be replaced when they have eroded by 25% or you can see the steel behind them. Cracked bricks are fine to use, unless the gap is wider than 3mm (if you can fit a £1 coin in the crack, this will require replacement) or deeper than 6mm, at which point the brick should be replaced.

All controls should be checked that they are free and smooth to operate.

The following consumable parts should be checked:

- Door Rope Seal
- Glass Seal
- Glass
- Fire Bricks
- Baffles

Only genuine Chesneys replacement parts should be used and are available from your Local Stockist or online: <https://chesneys.co.uk/category/stove-spare>

To find your Local Stockist log on to: [www.chesneys.co.uk/find-a-stockist](http://www.chesneys.co.uk/find-a-stockist) or phone 020 3177 4200.

## Door Rope Seal

Without a good seal around the door the stove will not work as designed and will lead to the glass blackening and a loss of control.

Over time the rope seal compresses and the seal between the door and the fire cube is compromised.

### Testing the Door Rope Seal

With the stove cold take a piece of paper, open the door and place the paper between the door and the stove. Close the door. There should be some resistance when pulling the paper out. This should be done on all four sides of the door. Where the paper is not trapped the rope can be gently plumped up by hand.

**Please note** - Always use gloves when handling ceramic rope.

If this does not work or the rope seal has come loose it may need to be replaced.

### Replacing the Rope Seal

Remove door and place face side down on a suitably protected table. Remove old seal and clean the rope seal channel thoroughly with wire a brush. Ensure the rope channel is clean and dust free.

Apply an even and continuous bead of glue in the channel. Place the new ceramic rope onto the glue, being careful not to stretch or twist the rope. Press the rope into the channel. Remove any excess glue.

Leave for 2 hours before refitting the door, allow 24 hours for the glue to dry.

## Cleaning

- **Never clean the stove when in use or hot.**
- **Under no circumstances should oil be used on any part of the stove which includes oil in an aerosol i.e. WD40. This will lead to a stove that will smell due to the oil getting hot and giving off an unpleasant odour.**
- The body of the stove should be vacuumed with a brush attachment; any marks should be wiped with a fine dry micro cloth.
- Under no circumstances should a damp/wet cloth be used on any steel or cast iron components
- The glass can be cleaned with damp newspaper dipped in the wood ash, or use a proprietary glass cleaner. The use of 0 grade fine wire wool is also a good solution to cleaning the glass. No abrasives should be used.
- Never empty the ash when the fire is alight.
- Always ensure the ash is cold before de-ashing. A scoop is provided with your stove to remove the ash from the base of the fire cube.
- Care must be taken when de-ashing or handling the bricks not to damage them as this may cause them to split or deteriorate faster.

## Stove Paint Application Instructions

Chesneys stove paint is quality, fast drying high temperature paint for use on wood, multi-fuel and gas stoves and other steel and cast iron products with in-service temperatures to 650°C. This product is not recommended for Vitreous Enamelled surfaces. Stoves, as supplied by the manufacturer, can be successfully repainted but problems can occur if painting the stove for the third time. Here it is necessary to remove most of the first two coats in order that the final paint thickness is not too great. If in doubt please contact your supplying dealer in advance of using this product for more information.

### Directions

Allow stove to go out and the surfaces to cool. Scrape off any loose paint. Lightly sand any existing sound paint to provide key. Remove all dust, dirt, rust and grease. It is essential that the surface is extremely clean. Protect surrounding furnishings and carpet from spray mist. This aerosol is designed to work at room temperature (20°C-25°C) and should be stored inside for several hours prior to use. Before spraying, shake can vigorously for 3 minutes after mixing ball rattles. This is especially important when using light colours as these have more pigments to mix. For best results the appliance also needs to have been stored in an environment to room temperature (20°C-25°C) for several hours prior to the painting process commencing. If painting steel flue sections then these will also need to be pre-heated. Ensure work area is well ventilated and you are not spraying near naked flames or any incandescent materials. Point spray nozzle towards object. Hold can between 300mm-375mm (12"-15") from surface to be painted. Press spray firmly. Use steady even strokes. Several thin coats give a better finish than one heavy coat. Do not apply more paint than is necessary. If clogging develops, remove spray nozzle with a twisting motion and clean. Never stick pins or sharp objects into the can. Gently replace spray nozzle with a twisting motion pointing away from you. After use, invert can and spray for a few seconds until no paint, only clear solvent, escapes. This will clean the tube and spray nozzle and allow for easier future use. During the painting process, while drying and for the first 3 times you use your appliance, open windows, doors and if necessary use fans to provide a fresh airflow, as the paint will give off fumes and smoke during the curing process.

Cure Process: Use kindling only on the first two fires which should burn for 15-20 minutes with the second burn being started whilst the appliance is still warm. A full fire should be burnt for 45-60 minutes, again starting while the appliance is still warm, then allowed to cool naturally. Your paint should have now cured and no longer give off fumes or smoke.

These application instructions must be followed strictly for successful application of Chesneys stove paint and the company can not be held responsible for incorrect storage, preparation, application and usage.

**7. STOCKIST & INSTALLER DETAILS**

Stockist Name and Contact Details:	Date of Purchase:
Installers Name and Contact Details:	Date of Installation:
Notes:	

Appropriate spillage test completed (✓):	YES	NO
Flue draught test completed (✓):	YES	NO
Pascal rating:		
Flue interference test completed and action taken:		
Appliance Serial Number:		
Instruction manual and tools explained to the customer and instruction on the stoves operation and limits (✓):	YES	NO

## 8. COMMISSIONING TESTING

Once a suitable flue draught has been established, and to ensure that during start-up operation and refuel that spillage does not occur, it is advised to carry out the following 3 step spillage test procedures and record the results using the form below. Before commencing the commissioning process, it is important for the installer to ensure the following have been met;

- ✓ The installer has read and understood this guidance document and has taken account of the guidance contained within the appliance manufacturer's installation instructions.
- ✓ A relevant risk assessment of the property and appliance has been carried out.
- ✓ The chimney, hearth and appliance is installed in accordance with the requirements of ADJ and their suitability/soundness has been verified as compliant.
- ✓ The air supply duct has been installed in accordance with the specification detailed by the appliance manufacturer and within manufacturer instructions.
- ✓ A CO alarm has been fitted.

Commissioning is the final stage of an installation and intended to evidence that the appliance works safely at the time the commissioning takes place. All dedicated external air supply installations are subject to the relevant commissioning and site testing provisions as required for under Building Regulations and are to be notified through a Competent Persons Scheme, where a certificate of compliance is to be issued, a copy retained by the installer and a copy left with the consumer for their records.

The commission procedure detailed below can be followed to confirm compliance for DEAS appliances. Further supporting information on commissioning may be available from recognised product specific manufacturer's instructions, and should be referenced during the commissioning process.

A copy of the form should be left with the consumer and a copy retained by the installer for their records.



### **Step 1 – Cold Spillage Test – Appliance Door Shut.**

1. Close all external doors and windows, internal doors to the room the appliance is located in and ensure all openable ventilators are closed and any devices that extract air from the dwelling are off.
2. Preheat the flue by lighting a small fire using kindling, a blow lamp or electric heater.
3. Light a small smoke pellet (5m<sup>3</sup>/30 sec), place into the appliance and shut the appliance door. All air-controls should be set to their maximum open position.
4. Check that all of the smoke enters the flue and none comes back into the room through any part of the stove, connecting flue pipe or air supply duct.

**Note:** *If visible smoke enters the room then repeat the flue preheat detailed in point 2 above, to generate additional flue draw. If the test still fails, progressively open a window in the room the appliance is installed. If the flue starts to draw the smoke, this will indicate a fault due to air starvation and the appliance is not being provided with adequate air for the flue to function correctly. Note the additional area of ventilation required and add permanently open ventilation into the room by that amount to correct the problem.*

5. If applicable, correct any highlighted issues and re-test using steps 1-4 above. If smoke continues to spill after opening a window, this indicates a more serious problem (i.e. flue blockage) which much be addressed and then this commissioning process repeated.

### **Step 2 - Extraction Test (Using a flue draught gauge)**

A flue pressure testing device shall be fitted to the flue of the appliance.

1. Ensure all doors to the room and all external doors, windows and air vents designed to be closable are closed, and all ventilation fans are switched off.
2. Light the appliance and allow for the optimum operating temperature to be reached.
3. The flue draught reading should be recorded and checked that it is in the parameters specified by the appliance manufacturer.
4. Open any internal doors interconnecting the room in which the appliance is installed to rooms where extraction fans are present within the property
5. Turn on all extract fans within the property to the maximum speed setting allowed.
6. Run the extract systems for ten minutes, and then, record the flue draught reading. The reading should not be lower than the previous reading obtained with extracts running and not fall below the parameters specified by the appliance manufacturer.

7. Once the tests confirm satisfactory operation, remove the test device and seal any apertures in the flue way if required.

**Note:** *If at any stage during commissioning the flue draught reading taken differs from the draught parameters specified by the manufacturer, action should be taken to locate the cause of the discrepancy and the installation rectified before proceeding with further testing.*

*The extraction test is a means to verify that the manufacturer's required flue draught during operation is met under the relevant conditions. In some cases spillage can still occur and so it is important to carry out the prescribed smoke spillage tests detailed.*

### **Step 3 – Hot Spillage Test - Refuelling**

Now that initial chimney draw has been verified as adequate, light a fire in the appliance using the recommended amount of kindling/small logs and manufacturer's recommended air control position and allow the appliance to reach its normal operating temperature. At the end of the banking period and before refuelling;

1. Close all external doors and windows, ensure all openable ventilators are closed.
2. Open the appliance door and with a smoke match/pen (15 sec burn time) pass over the top and side edge of the opening of the combustion chamber, observe and record if the smoke/combustion products are drawn into the chimney or spill back into the room. Once the smoke is extinguished, close the appliance door.
3. Repeat this test with all extraction fans running and internal doors open connecting the room the appliance is installed in to the extraction device(s) (see extraction test above).

**Note:** *If smoke or combustion enter the room, then additional ventilation may be required to compensate for the extraction device(s). This can be tested by gradually opening a window and observing the relevant smoke patterns during operation.*

*If the smoke continues to fail to draw up the flue, or fails with additional ventilation beyond that advised by ADJ Table 1, thoroughly inspect the flue/ chimney and termination for other faults.*

*Check the appliance/flue/chimney draw with a flue draught gauge and ensure draught is within manufacturer's guidelines. If no gauge is available, or no draught reading is given, you can test with smoke as a "safety check" but there is no substitute for using the correct tools and undertaking the correct tests.*

## On Site Verification of HETAS Spillage Test Procedure

1. Property Details	
Address:	
Installation Location:	
Installation Type:	
Assumed Dwelling Permeability Low to High (see risk assessment document and guidance):	

Appliance Details	
Appliance Type:	
Make/Model:	
Fuel:	<i>Wood</i>
Nominal Output (kW):	
Gross Efficiency (%):	
Freestanding/Inset:	
Air Control Type:	<i>Manual</i>

Commissioning Details					
	Compliance (please circle)		Notes / Measurements		
	Extract Off	Extract On	Extract Off	Extract On	Manufacturer Specified
Extraction Test	<i>Pass / Fail</i>	<i>Pass / Fail</i>			
Cold Spillage Test	<i>Pass / Fail</i>	<i>Pass / Fail</i>			
Hot Spillage Test	<i>Pass / Fail</i>	<i>Pass / Fail</i>			

## 2. Direct Air Supply Details *(if applicable)*

Ducting Length:	
Number of Bends:	
Combustion Air Requirement: (mm <sup>2</sup> )	
Room Sealed	<i>Yes / No</i>
<i>If No</i> , Extra ventilation to room (mm <sup>2</sup> )	
Incompliance with manufacturer's instructions	<i>Yes / No</i>

## 3. Installation Details

	Compliance (please circle)
In compliance with manufacturers instructions?	<i>Yes / No</i>
In compliance with ADJ?	<i>Yes / No</i>
Direct External Air Supply Present? (see section 5)	<i>Yes / No</i>

## 3. Declaration

Name:			
Company:			
HETAS Operative No:			
Signed:		Date:	
Other Notes / Comments:			



## 10. GUARANTEE

Your Chesneys stove comes with a 12-month manufacturer's guarantee, which includes consumables. This is valid from the date of installation. An extended 10-year warranty (inclusive of the initial 12 months), to cover the stove fire cube/box against cracking, splitting and warping, is available by registering the appliance.

Please be aware this extended warranty has to be activated within 28 days of installation.

This extended warranty is not applicable if purchased through an unauthorised dealer/stockist

The extended warranty is based on normal domestic use. Products used in a commercial setting are not eligible for our extended warranty.

If any part of the fire box/chamber fails due to manufacturing or material defect within the extended warranty period CHESNEYS will at its sole discretion either repair or replace the part at no charge. The decision of CHESNEYS will be final. For the purpose of this extended warranty, a material or manufacturing defect includes the splitting or cracking of the main stove body.

The above points are all subject to an annual service and sweeping of the chimney being performed by a qualified individual. Should this essential maintenance NOT be completed, the outlined extended warranty terms above will be considered void, and the standard 12-month guarantee will apply to the product.

Removal and re-installation costs will only be covered during the first year only if found to be a manufacturing fault. Cover for the remaining 9 years will be for parts only.

Items such as fire bricks, baffles, glass, seals, ash pans and grates are consumable items and are not covered by a guarantee/warranty. These items will deteriorate over time and will need replacing. The length of time that these parts last will depend on the type of fuel used, and how hot and long the stove is left to run. The firebricks, rope seal and primary baffles are subjected to a huge amount of stress while the stove is under fire and will appear stressed quite quickly and the bricks can sometimes crack. This does not mean their integrity is compromised and they will have plenty of life left in them. The bricks should be replaced when they have eroded by 25% or you can see the steel behind them. Cracked bricks are fine to use, unless the gap is 3mm or greater at which point the brick should be replaced.

In normal usage the paint finish of your appliance may change colour slightly. As these circumstances are considered normal, they are not covered by the guarantee. The paint finish will require touching up or repainting from time to time. Maintaining the finish is normal practice and is not covered by the guarantee.

Full terms and conditions can be found at <https://chesneys.co.uk/warranty-registration>

## **11. Disposal/Recycling**

After the product life of the appliance has expired, please ensure that the items are disposed of correctly. Parts will need to be separated out into material groups before disposal. Each appliance will be made up of the following materials: glass, fibre glass, cast iron, stainless steel, steel, brass and aluminum.

Make sure you use suitable gloves when handling any sharp metal, glass, or fibre glass. Seek assistance or a professional disposal service if the item is too heavy for you to handle.

Always dispose of these items in the most sustainable way possible, and in a way which is in line with current environmental protection/regulations and any recycling, reprocessing or disposal technologies.

### 13. WARRANTY REGISTRATION

To validate and start your warranty please fill out this form and send it back to:

**Chesneys (Warranty Registration)**  
**Unit 12-16 Eldon Road,**  
**Beeston,**  
**Nottingham, NG9**  
**6DZ**

Alternatively you can register your stove online via the Chesneys website by completing the online form:

<https://chesneys.co.uk/warranty-registration>

All items are required:

Your Details	
Name	
Address	
Postcode	
Telephone No.	
Email	

Purchase Details	
Purchased From	
Purchase Date	

Product Details	
Appliance Name	
Appliance Colour	
Serial Number*	

Installation Details	
Installed by	
HETAS/OFTEC registration no.	
Installation date	
Is the flue lined?	YES / NO

\*The serial number can be found on the data plate which is located on the rear lower left corner of the stove, this plate can be swivelled and viewed from the front. The Double Sided 8 Series stove data plate can be found under the stove on the left viewed from the air control in the middle and also can be swivelled to reveal the serial number.



