

CHESNEYS

GAS EFFECT STOVES CUBE

INSTALLATION & USER MANUAL

IMPORTANT:

PLEASE ENSURE YOU REGISTER FOR YOUR EXTENDED WARRANTY. PLEASE SEE PAGE 58 & 59 FOR DETAILS

www.chesneys.co.uk

Technical Manual
Technical PIN: 0359DP0050

User and Installation Instructions

Model No.
Cube Gas Stoves:
Sanctuary
Shoreditch
Salisbury
Serendipity

IMPORTANT:
Please read these instructions
carefully before installation or use.

These instructions are only valid if the
following country code is on the appliance.

This appliance must be installed and serviced by a qualified
person in accordance with local and national regulations.

The flue system must be installed and inspected by a qualified
person in accordance with local and national regulations.

Contents

Section	Pages
1. Unpacking	5-6
2. Technical Data	7
3. Installation Parameters	8-10
4. Burner and Control Information	11-12
5. Construction Information	13-17
6. Appliance Details	18
7. Preparing the Appliance for Installation	19
8. Installation	20-27
9. Placement of Fibre Logs, Chippings and Embers	28-32
10. Commissioning the Fire Unit	33-34
11. Briefing and Handover to the Customer	35
12. Servicing and Maintenance	36-38
13. Fault Finding	39-40
14. User Instructions	41-44
15. Control System Information / Operating Instructions	45-53
16. Installer Commissioning Checklist	54
17. Annual Service Record	55-57
18. Chesneys Warranty Information and Registration	58-59

1. Unpacking

Remove the appliance from its packaging, check that it is complete and undamaged.

If satisfied by the condition and the contents is as specified, proceed with the installation.

The installation should only be carried out by a competent person and all gas work must be carried out by a Gas Safe registered person in accordance with national and local regulations for both gas and electricity (If required).

The installation must comply with local and national building regulations.

For the Republic of Ireland, reference should be made to IS813 and ICP3 and any guidance notes from Board Gais.

Failure to comply with the regulations nullifies ALL guarantees.

Parts:

Fig.1 Gas Stove Appliance



Fig.2 Installation Manual / Warning Label

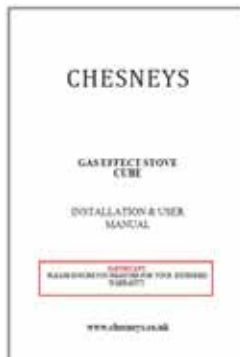
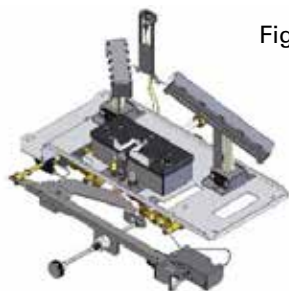
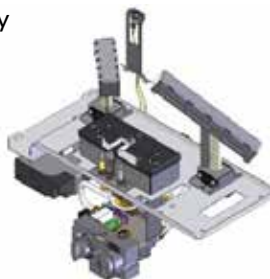

Fig.3 Burner Assembly



Slider Control

or



Merit Control

Fig.4 Logs



Fig.5 Bag of embers



Fig.6 Remote Control Handset (Automatic version only)



Fig.7 Glow strands



2. Technical Data

Gas Connection Size	8.0mm O.D. tubing
Control System	TESA (Teddington Control) GV60 (Mertik Maxitrol)
Appliance Mass Range (kilograms)	79kg – 155kg

Gas Type	Gas Category, Type and Supply Pressure	Countries of Destination	
		GB	NI
NG	I _{2H} - G20 at 20mbar	✓	✓
LPG	I _{3B/P(30)} - G30/G31 at 30mbar	✓	✓
	I ₃₊ - G30/G31 at 30/37mbar	✓	✓
	I _{3P(37)} - G31 at 37mbar	✓	✓

CUBE GAS STOVE CONVENTIONAL FLUE									
Gas Type	Gas Category, Type and Supply Pressure	Heat Input Gross kW	Heat Input Nett kW	Gas Rate m ³ /h	Burner Pressure	Injector marking	Pilot Assembly	Efficiency Class	NOx Class
NG	I _{2H} - G20 at 20mbar	6.9	6.2	0.648	17	Centre Burner 100 Log L/H 180 Log R/H 180	Polidoro 440.1350.24	1	5
LPG	I _{3B/P(30)} - G30/G31 at 30mbar	6.6	5.9	0.18	28	Centre Burner 80 Log L/H 100 Log R/H 100	Polidoro 440.1350.24	1	5
	I ₃₊ - G30/G31 at 30/37mbar	6.6	5.9	0.18	28				
	I _{3P(37)} - G31 at 37mbar	6.6	5.9	0.24	36				

3. Installation Parameters

This appliance must be installed in accordance with the rules in force and used only in a sufficiently ventilated space. Consult instructions before installation and use of this appliance.

NOTE - Wear protective clothing when fitting or carrying works out on the appliance.

For your safety it is law that all gas appliances must be installed by a competent person.

Before installation, ensure that the local distribution conditions (identification of the type of gas and pressure) and the adjustment of the appliance are compatible.

The installation must be carried out in accordance with the relevant local and national specifications and comply with current Building Regulations.

Chesneys recommend the fitting of a Carbon Monoxide detector that conforms to EN 50291 wherever a gas appliance is installed.

Due to the unpredictability of the draught in existing flues and chimneys Chesneys recommends the use of a liner for this product in accordance with local and national regulations.

NOTE - The flue must not be shared with any other appliance.

If the chimney has been used for solid fuel, the chimney must be swept before installation.

The flue must be fitted in accordance with local and national regulations. Damper plates or restrictor plates must not be fitted in the flue.

The flue must be inspected by a competent person and passed for use with the appliance.

It is advised that a flue specialist inspect the flue system on an annual basis to ensure that the flue system is sound and the combustion products outlet (terminal) is clear of obstruction.

The flue system should only be fitted to the appliance where the chimney serving the appliance:

- a) Has passed a flue flow test to ensure that the flue is sound and without leaks; and
- b) Has been swept if previously used for solid fuel.

The flue system must be constructed from the appliance upwards, with all joints being fully locked and sealed using the Chesneys specified parts.

Do not install the appliance in a bathroom or a room that contains a bath or shower, as the moisture in the atmosphere can affect the combustion process.

It is advised that provisions be made for the removal of the appliance without the need to dismantle the flue system.

Before the appliance is installed, the flue / chimney must be inspected to ensure that it is structurally sound and free from obstructions.

Ensure the builders opening and supports are made of non-combustible and heat-resistant material.

Do not cover the appliance and or do not wrap it in an insulation blanket or any other material.

Do not make any changes to the appliance.

The gas connection must be in accordance with local and national regulations.

VENTILATION

GB current British Standard BS5440 appliances classified under 7kW (net) do not require permanent ventilation.

NOTE - Ventilation requirements in other countries may vary please consult with national regulations in your country.

WARNING - SPILLAGE MONITORING SYSTEM

The spillage monitoring system/device fitted to this appliance is designed to shut off the appliance if the evacuation of products of combustion is disturbed. This is not adjustable and must not be put out of action.

When using stone like materials and or plaster finishing, the chimney breast should dry for at least 6 weeks to prevent cracks.

The appliance is not fitted with an integral guard. It is recommended that a guard be used for the protection of young children, the elderly or infirm and also for normal use conforming to BS8423:2002, such that access to the hot appliance is minimised.

Do not place combustible materials directly in front of the appliance.

In case of a damaged or broken glass, do not use the appliance and isolate the gas to the appliance.

Clean the glass before you use the appliance in order to prevent dirt from burning on the glass.

All appliances are supplied with a metal data plate attached to it and must remain with the appliance.

Fig.8
Data Plate

The Data plate for the appliance is located at the rear of the stove on a metal plate that swings outwards.

THIS APPLIANCE MUST BE INSTALLED IN ACCORDANCE WITH THE RULES IN FORCE AND ONLY USED IN A SUFFICIENTLY VENTILATED SPACE. CONSULT INSTRUCTIONS BEFORE INSTALLATION AND USE OF THIS APPLIANCE.						
COUNTRIES OF DESTINATION GB & NI	CHESNEYS 194-196 Battersea Park Road, London, SW11 4ND Tel: 020 7627 1410 www.chesneys.co.uk				UK CA 0359-24	
	CUB GAS STOVE C/F LOG BURNER					
MODEL: (<input checked="" type="checkbox"/>)	SANCTUARY	SALISBURY	SHOREDITCH	SERENDIPITY	BEAUMONT	
GAS CATEGORY, TYPE AND SUPPLY PRESSURE		HEAT INPUT (GROSS) KW	HEAT INPUT (NETT) KW	GAS RATE M ³ /Hr	BURNER PRESSURE MBAR	EFFICIENCY CLASS
I2H - G20 @ 20 MBAR		6.9	6.2	0.648	17	
I3BPP/P (30) - G30/G31 @ 30 MBAR		6.6	5.9	0.184	28	1
I3+ - G30/G31 @ 30/37 MBAR		6.6	5.9	0.184	28	
I3P (37) - G31 @ 37 MBAR		6.6	5.9	0.24	36	
SERIAL NUMBER:				PIN: 0359DP0050		
SPILLAGE TEST TEST THE APPLIANCE FOR SPILLAGE AFTER AN INITIAL 10 MINUTES OF OPERATION ON A MAXIMUM RATE. PLACE A SMOKE MATCH INSIDE OF THE THE DRAUGHT DIVERTER AT THE REAR OF THE APPLIANCE. THE SMOKE SHOULD BE DRAWN INTO THE APPLIANCE. IF SPILLAGE OCCURS TURN OFF THE APPLIANCE AND REFER TO THE INSTALLATION MANUAL.						

4. Burner and Control Information

Fig.9

Slider Control
Burner information

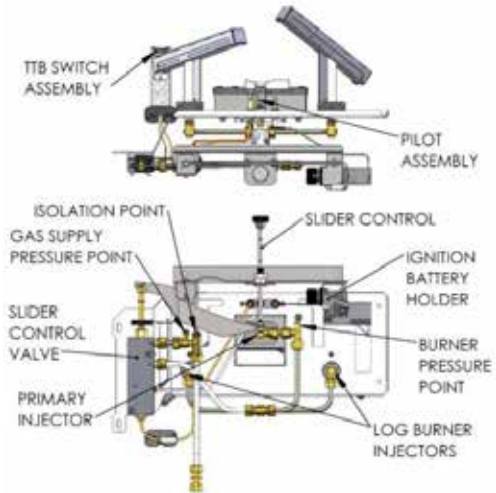
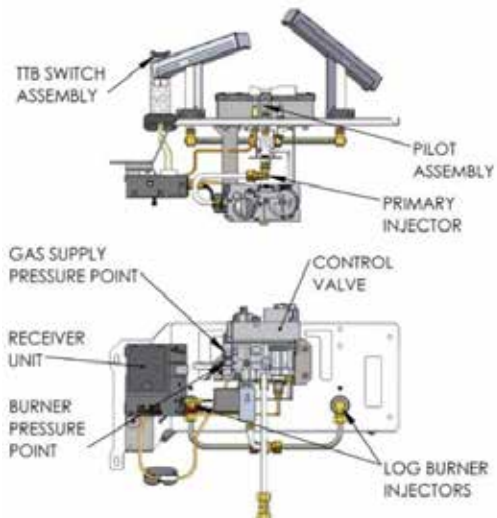

Fig.10

Mertik Control
Burner information



Dimensions

Fig.11

Slider Control Burner
information

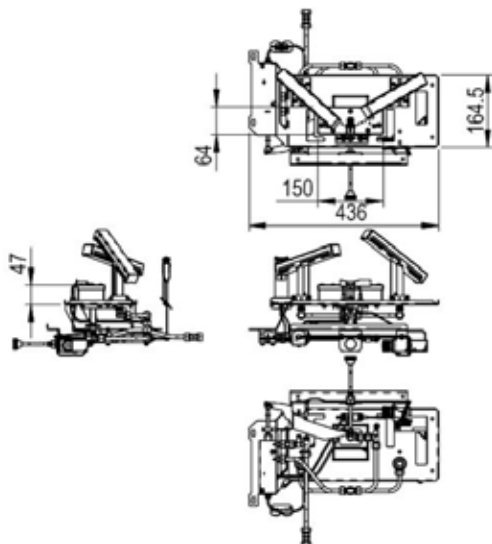
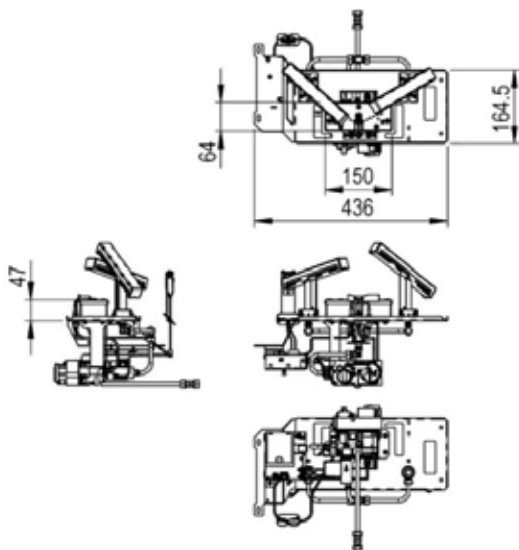

Fig.12

Mertik Control Burner
information



Construction Information

Hearths

A hearth shall be provided according to National regulations, in Great Britain this would be to Building Regulation Document J and BS5871-1. A Hearth shall be provided for the stove extending to at least the front of the supporting legs, and to at least each side of the stove. The edge of the hearth should be marked to provide a warning to the building occupants and to discourage combustible floor finishes such as carpet being laid too close to the appliance. A way of achieving this would be to provide a change in level.

Chesneys recommend a hearth footprint 50mm more on all 4 sides than the footprint of the appliance. The hearth shall have a minimum thickness of 12mm.

Emissions Exit Connection Types: Conventional Flue Only

The appliance is designed to be installed into a Class 1 Conventional flue system that has been lined with a minimum 5" flue liner, or a minimum 5" factory made flue system conforming to BS 5440-1. The connection to the flue spigot should be via a 127mm (5") diameter stove pipe connecting to the flue liner at the register plate or to the linerless kit.

If the appliance is used with an existing lined chimney the minimum flue diameter must be 6" (152.4mm) or above to accommodate the 5" liner.

NOTE-The minimum height of the flue system is 3 meters from the spigot. The maximum height should be governed by the draw on the individual flue during the effectiveness of smoke removal/testing of the flue.

A smoke pellet can be used to test the flue for effectiveness of the draw, light the smoke pellet and place to the base of the chimney/liner. Check other parts of the dwelling (including loft areas) for leakage, down draught etc. If the smoke is drawn into the chimney/liner without problem, continue with the installation.

If there is little or no flow into the chimney preheat the chimney and repeat the smoke test. If there are still issues with the draw seek expert advice.

NOTE –The smoke test gives a fair idea on the draw, but is no guarantee that the products of combustion from the appliance will clear. A spillage test is also required after the installation.

If spillage occurs after installation contact the manufacturer for advice.

The Builders Opening

Use non combustible heat resistant materials for the chimney breast, including the top of the chimney breast, the material in the chimney breast and the back wall of the chimney breast. The construction must comply with all relevant regulations.

Conventional Class 1 Chimney (lined only) / Linerless Kit / Factory made flue system conforming to BS 5440-1.

Fig.13

Installed into a chimney recess / builders opening (see Fig.15 for installation details)

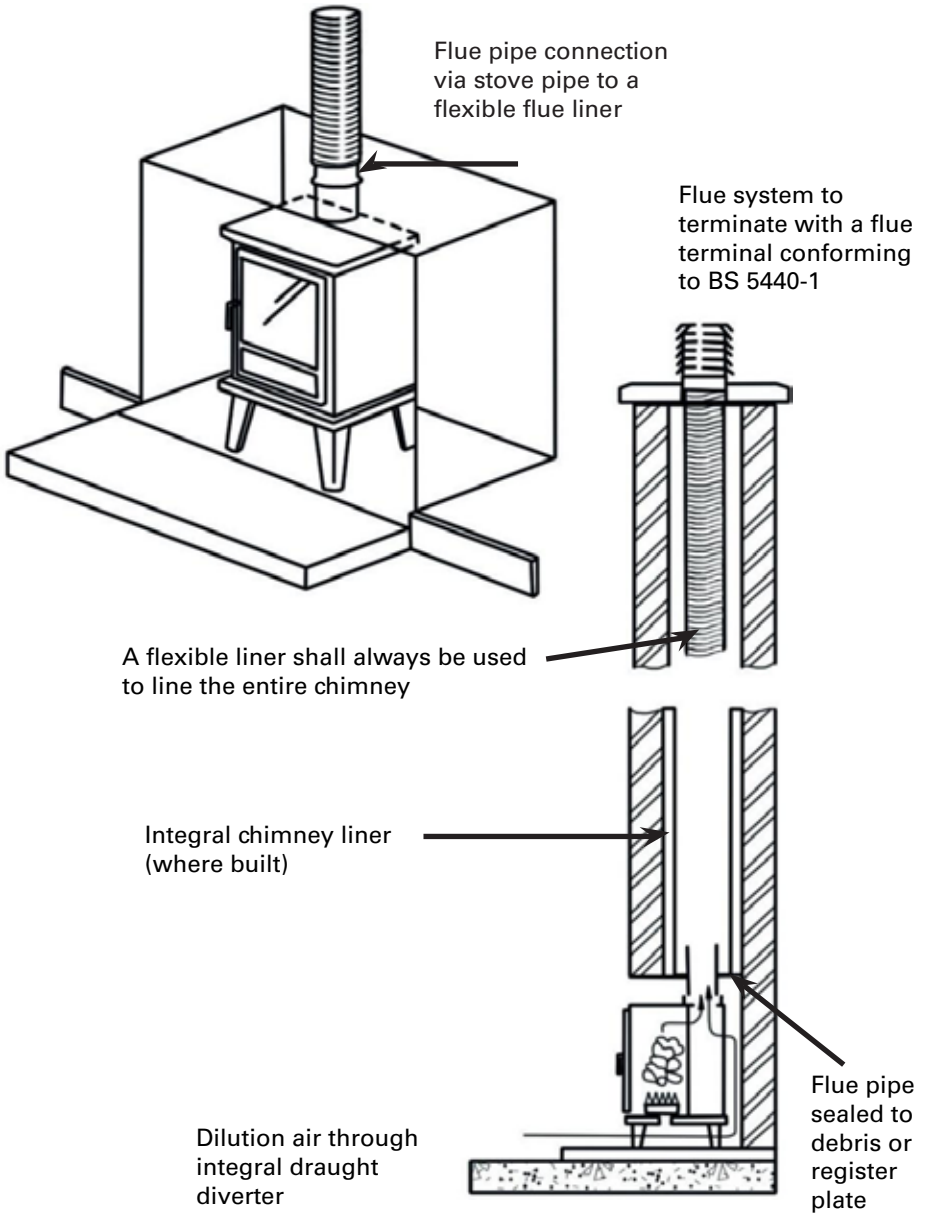
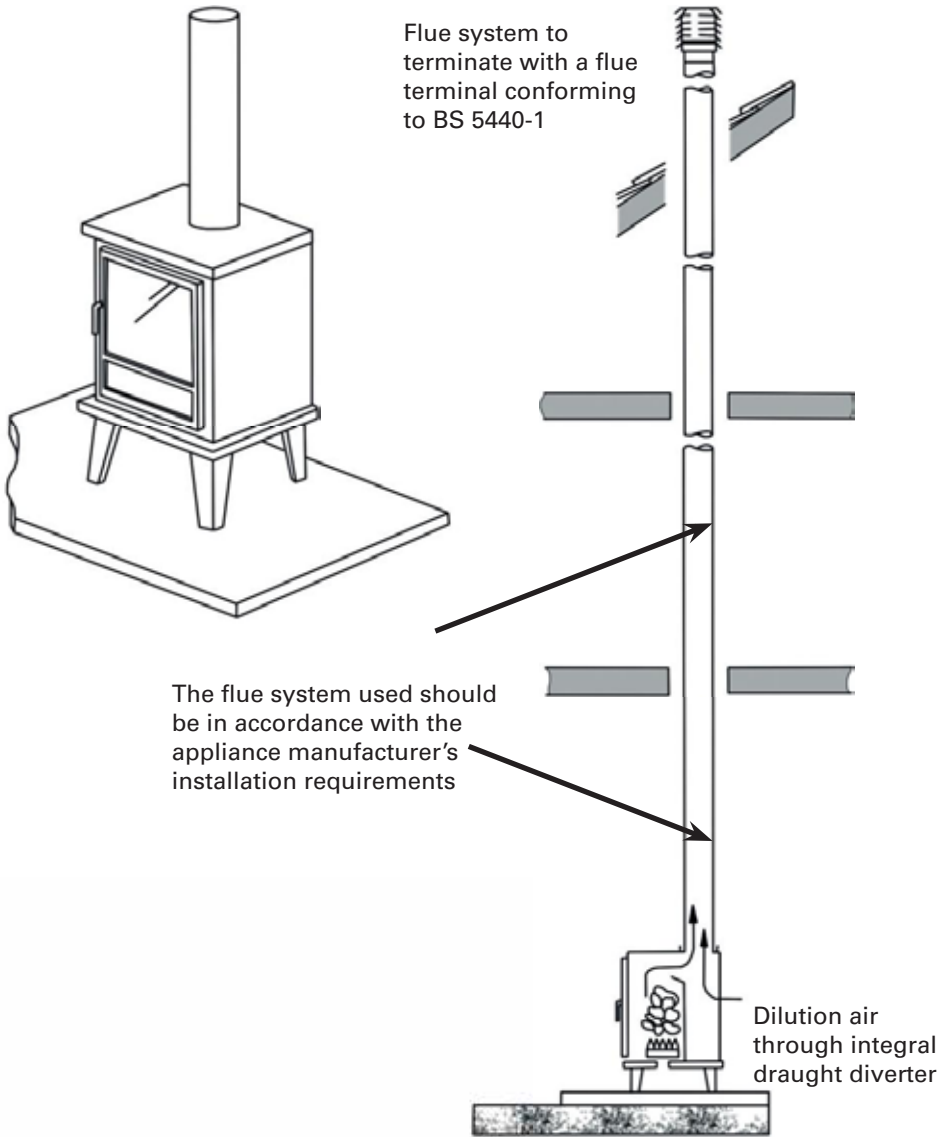

Fig.14

Free standing installation connected to a factory made flue system.



1 Meter Conventional Flue Linerless Kit Connection

Flue & Chimney Requirements for a Chesneys Linerless Kit

- Make an assessment of the chimney ensuring it's clean and free of obstruction. If not the chimney must be swept prior to installation.
- Any restriction or damper plates must be either removed or locked in the permanently open position.
- Due care should be taken when using a linerless flue to prevent condensation forming. Do not fit a linerless flue kit in a chimney taller than 10 metres external wall or 12 metres internal wall.
- The required flue connection for this is a 127mm (5")
- THESE STANDARDS SHOULD CONFORM TO BS 5440 Part 1.

UNDER NO CIRCUMSTANCES MUST THE LINERLESS KIT BE USED WITH ANY INSTALLATION OTHER THAN AN EXISTING MASONRY CHIMNEY WHICH HAS A MINIMUM DIAMETER OF 178mm (7"). THE CHIMNEY MUST BE SOUND AND CLEAN. IF PREVIOUSLY USED FOR SOLID FUEL, IT MUST BE SWEEPED PRIOR TO PROCEEDING WITH THE INSTALLATION

Fig.15

Conventional Flue options: Lined chimney/Linerless Kit

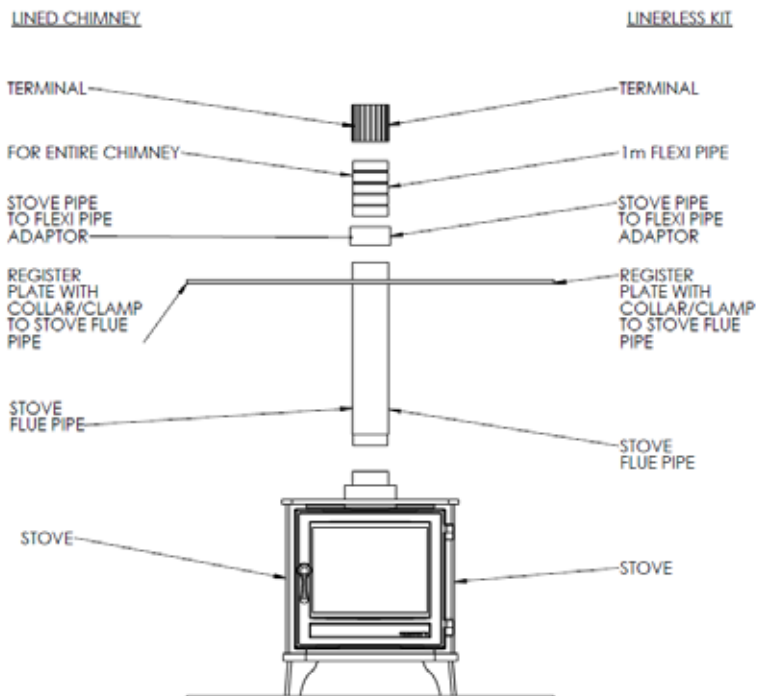

Appliance distances and clearances

The minimum distances to combustibles are given in the table below. Distances to noncombustibles should conform to local and national building regulations.

Due to the nature of the appliance most part of it will become hot during normal operation, therefore the entire appliance is classed as a working surface.

Cube Gas Stove	Combustibles
Rear of appliance	100mm
Side of appliance	75mm
Above the appliance	200mm
Shelf height above appliance	300mm
MINIMUM CLEARANCE TO BE STRICTLY MAINTAINED AT REAR OF APPLIANCE TO NONCOMBUSTIBLE IS 50MM FOR CORRECT OPERATION AND AIR FLOW. IF THIS IS NOT ACHIEVABLE THE APPLIANCE MUST NOT BE INSTALLED!	

Please Note: The depth of the shelf should not project more than 250mm from the front face of the fireplace opening.

Gas Route

For your safety it is law that all gas appliances must be installed by a competent person, in accordance with the current Gas Safety regulations applicable in the country of use.

Ensure that the gas supply is capable of delivering the required amount of gas, and is in accordance with the rules in force.

When laying the gas pipe work check the fire unit's gas inlet location to ensure a smooth run.

The gas inlet connection is located below the burner assembly. This can be accessed via the stove door or under the appliance. The pipe should run under the appliance and connect into the inlet connection of the 8mm fitting provided. The gas pipe can be routed from any direction below the appliance as the inlet connection is flexible to accommodate various positions.

An isolation valve or valves must be fitted near to the appliance in an accessible area, meeting all local and national regulations this is to allow the complete removal of the burner control assembly, for maintenance or repair.

6. Appliance Details

Fig.16

Appliance dimensions

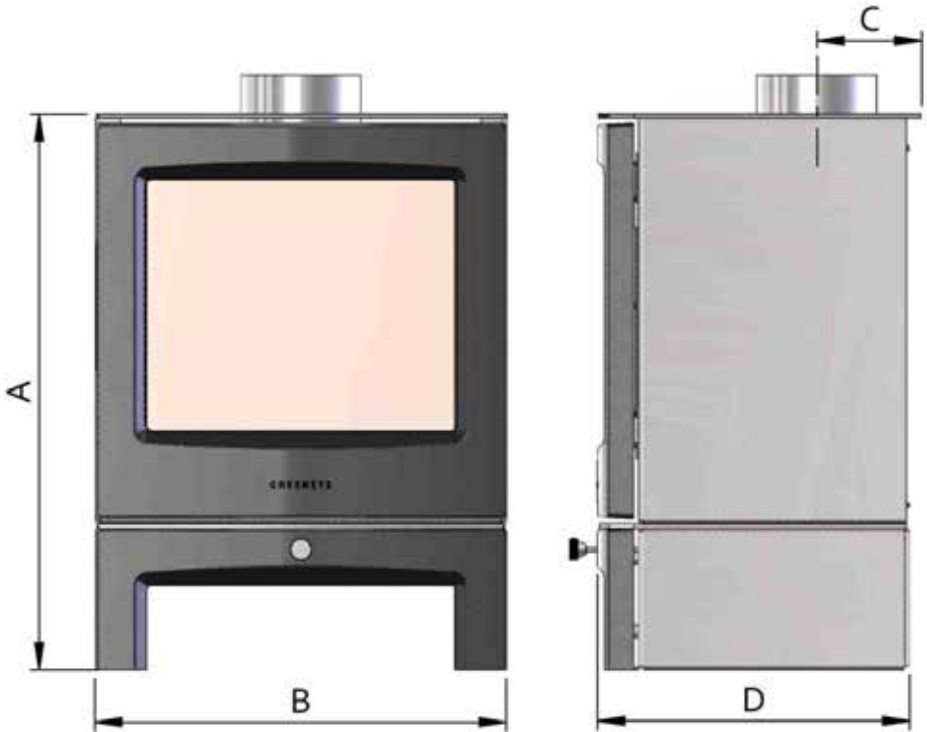

Cube Gas Stoves	A mm	B mm	C mm	D mm	-	-
Sanctuary	650	480	122	380	-	-
Salisbury	600	500	122	420	-	-
Shoreditch	665	492	122	366	-	-
Serendipity	655	492	122	371	-	-

7. Preparing the Appliance for Installation

The appliance is supplied in separate boxes, stove, burner assembly, logs set. The installer is required to install the burner and logs into the appliance.

Important Notes

Ensure the glass is clean on both sides before lighting as dirt, oils etc. can etch the glass.

Do not clean with abrasive materials as this can accelerate dirt accumulation and weaken the glass.

The appliance should be placed in the correct installation position, taking into account the flue connection and gas connection.

The door can be opened by pulling forward, the glass assembly will need to be removed by removing the 8 fixings as shown below.

Fig.17

Removal of Glass Panel

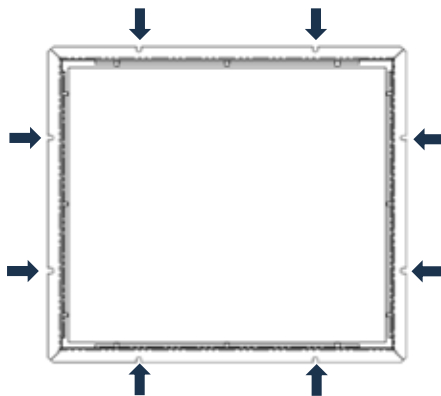

8. Installation

IMPORTANT Please ensure the gas pipe has been routed and the flue connection is terminated in a suitable position ready for connection.

Fixing of the appliance

The gas stove is a free standing appliance and does not require any additional fixing to the floor or walls.

Flue connection for conventional flue models

Place the appliance in the installation position ensuring the top lid is installed.

The appliance spigot should only be connected to a suitable flue system using a suitable stove pipe and register plate as illustrated in (Fig15).

At this stage the connecting pipe should be cut to the desired length.

The flue pipe will need to be placed into the appliance spigot, ensuring a minimum insertion depth of 50mm. The joint between the flue pipe and the appliance spigot is to be sealed with a suitable high temperature sealant. The flue must be sealed to the appliance to ensure the products of combustion do not enter the room.

Gas Connection

NOTE – All gas work must be carried out by a qualified gas installer to all relevant regulations.

Ensure that the gas supply is capable of delivering the required amount of gas and is in accordance with the rules in force.

An isolation valve or valves must be fitted near to the appliance in accordance with national regulations to allow the complete removal for maintenance or repair.

The Slide control models are fitted with a combined isolation/pressure test point as part of the burner assembly, connect the gas inlet to the correct connection shown with 8mm rigid pipework.

Fig.18



Connect the main gas valve inlet either directly to the gas isolation valve or via the flexible gas pipe using a suitable coupling as shown in below.

Fig.19

Appliance



Gas supply pipe

Soundness testing

At this stage gas soundness test can be performed, connect a suitable test meter to the pressure test point ensuring the tube is routed under the main body of the appliance and not through the door. Carry out a soundness test, on completion leave the meter connected.

IMPORTANT

Only continue with the installation if soundness performance is satisfactory.

Fig.20

Fitting the Burner and Grates

The two options of stove include:

1. Slide Control Burner
2. Mertik Control Burner (Automatic)

Fig.21a

Slide Control Instructions

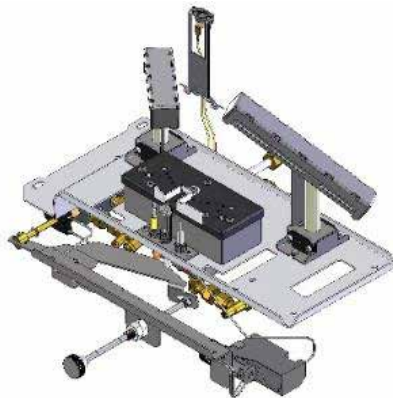

1. Fit the burner into the stove and secure with the 4 fixings provided, then connect to the gas supply and carry out relevant tests.



- Fit the TTB (spillage monitoring device) bracket through the hole in the rear panel on the left hand side of the stove and fix with 2 fixing bolts provided. Rear view of TTB (spillage monitoring device) bracket correctly positioned.

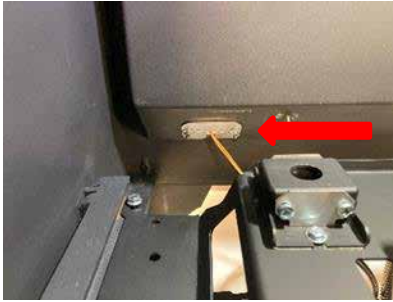

- Remove the set screw that has been fitted to the Actuator adaptor. Connect the actuator mechanism to the actuator adaptor aligning the slotted hole in the mechanism into the center slot of the actuator adaptor, secure using the set screw provided ensuring the screw is inserted into the threaded side of the adaptor then through the actuator mechanism through to the actuator adaptor clearance side.

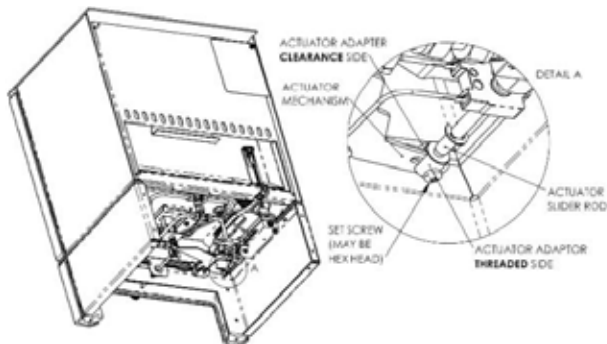
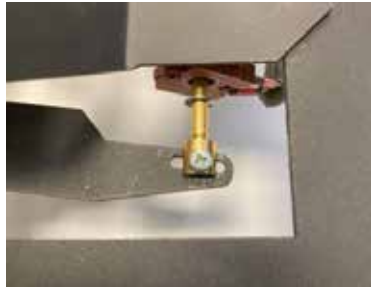

4. The spark generator will need to be mounted onto its bracket, which is located at the bottom right hand side of the stove

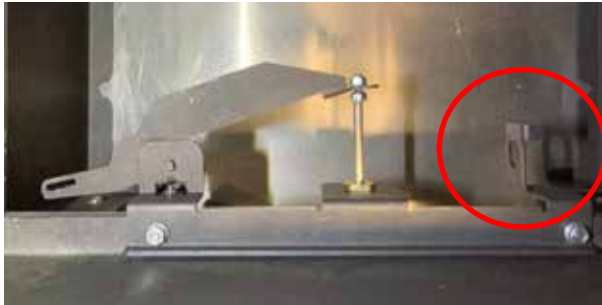

5. Remove the cap and locking nut from the battery compartment of the spark generator



6. Mount into bracket as shown, A) Place lock nut into position, B) Insert battery C) Fit the cap

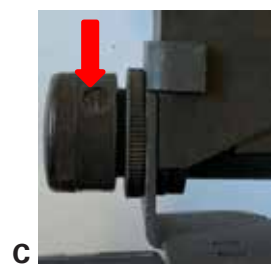
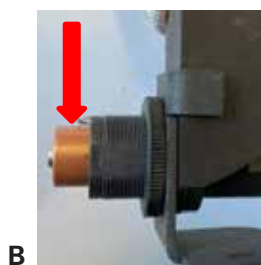

7. Fit the left and right grate assemblies into the stove with the inserts at the front.

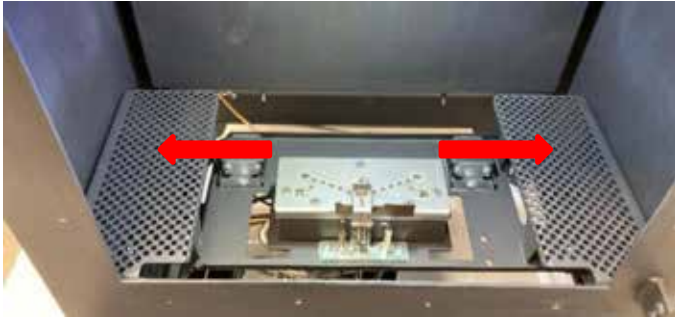

8. Fit the middle grate into the stove



9. Fit the pistol burners through the key holes in the middle grate, ensuring they are fully located onto the burner ports. The shorter pistol is to be placed in the left port and the taller pistol on the right.



Fig.21b

Mertik Control Burner Instructions

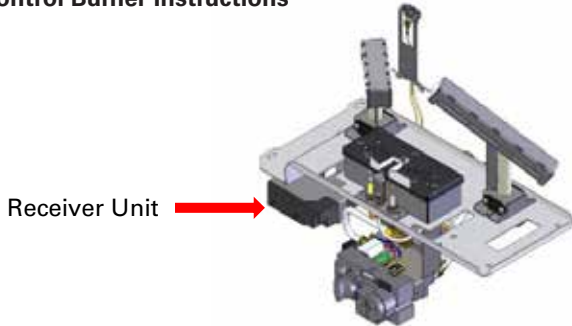

Please inset the batteries into the receiver unit prior to fitting the burner into the stove.

1. Fit the burner into the stove and secure with the 4 fixings provided, then connect to the gas supply and carry out relevant tests.

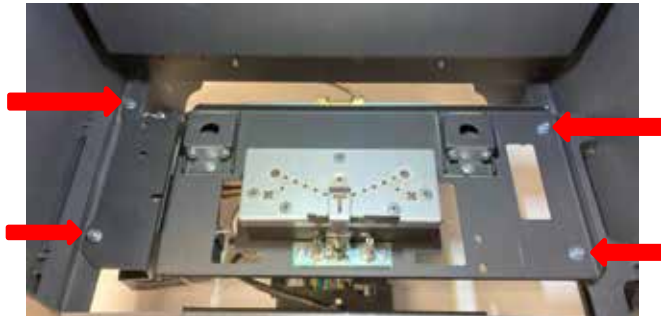

2. Fit the TTB (spillage monitoring device) bracket through the hole in the rear panel on the left hand side of the stove and fix with 2 fixing bolts provided.



3. Rear view of TTB (spillage monitoring device) bracket correctly positioned.



4. Fit the left and right grate assemblies into the stove with the inserts at the front.

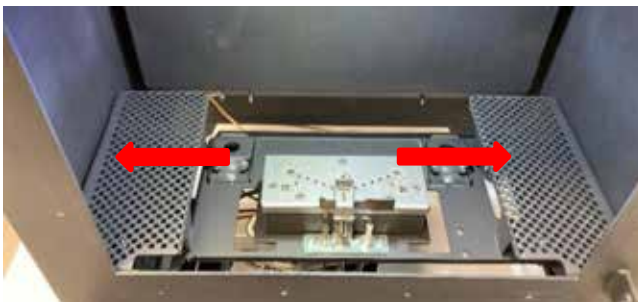

5. Fit the middle grate into the stove.

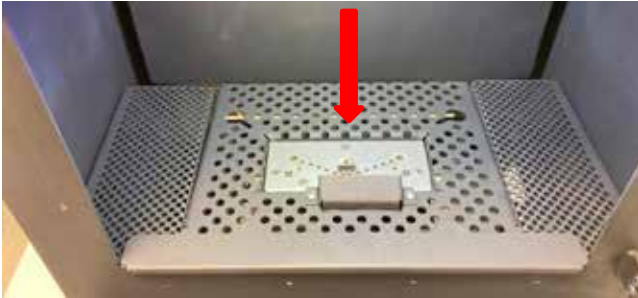

6. Fit the pistol burners through the key holes in the middle grate, ensuring they are fully located onto the burner ports. The shorter pistol is to be placed in the left port and the taller pistol on the right.



9. Placement of Logs & Embers

Logs and embers are only available from Chesneys Stockists.

Important Notes:

The placement of fibre logs and embers must be installed in accordance with these instructions;

any deviation may cause poor combustion. If any of the components are broken **DO NOT INSTALL.**

Do not to add more fibre logs onto the fire bed than specified.

Please be cautious when applying glow strands in and around the pilot assembly, as this can lead to ignition problems causing the appliance to enter error status. Visuals of the pilot assembly must be completed when commissioning or servicing the appliance.

Fitting the log base for the Cube Gas Stove Embers / Glow Strands

Place the embers on to the burner tray and spread the embers evenly across the tray bed, ensuring not to fully cover the burner ports.

The embers provided are to be placed in a single layer on the top of the burner bed, any remaining embers should be kept as spares. Place some of the glow strands over the embers.

Fig.22



Fitting the log set for the Cube Gas Stove

Fit the log set according to the following details.

Fig.23

Log Identification



The overall log set up should replicate the image below.

Fig.24



1. Fit Log 1, centrally under the pistol burners and behind the primary burner.

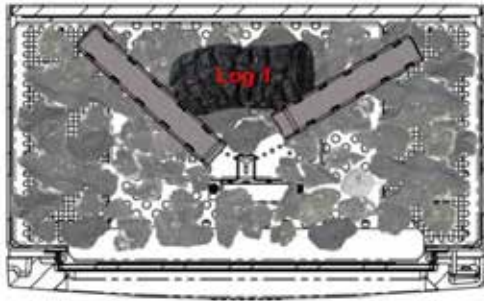

2. Fit Log 2, in front of the primary burner and positioned to the right of the appliance.

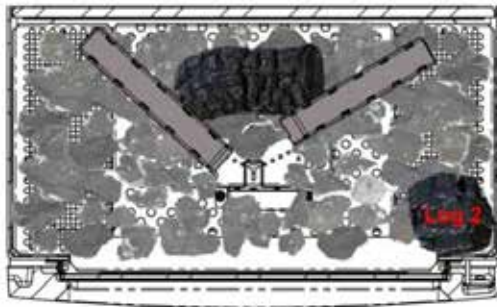

3. Fit Log 3, in between the right hand pistol burner and log 2.

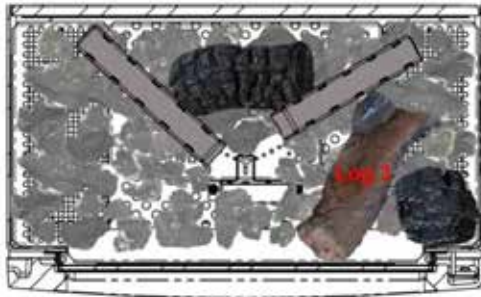

- Fit Log 4, to the left of the appliance

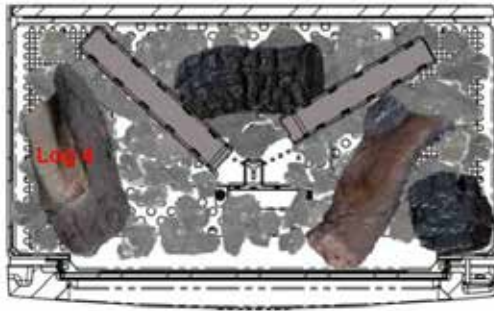

- Fit Log 5, in front of the primary burner, to the left of log 3, lying in front of the pilot shield.



- Fit Log 6, the left hand side of the log rests on log 4, the right hand side of the log rests under the Pistol burner.



- Fit Log 7, the left hand side of the log rests on the burner bed in front of log 1, with the right hand side of the log resting on log 3.

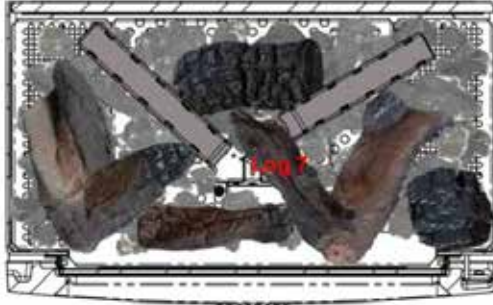

- Fit Log 8, on top of the left hand log burner pistol.



- Fit Log 9, on top of the right hand log burner pistol.



The log arrangement is now complete, make sure the pilot assembly is left clear and that the pilot assembly smoothly lights the primary burner and that the primary burner smoothly ignites both log burners.

10. Commissioning the Fire Unit

Check the gas supply and gas appliance for soundness.

The appliance must be fully fitted; the door of the appliance must be sealed.

Check that there is no movement of the door or gaps in the seal.

Check that all the products of combustion are entering the flue and that no products of combustion are entering the building.

Lighting the appliance for the first time

IMPORTANT NOTE - Do not run the appliance with the glass panel open, or damaged.

When lighting the appliance for the first time, the materials (i.e. paint, sealants etc.) will give off smoke and an unpleasant odor. This is quite normal and will disappear after continuous use. This process can take several fires and will depend on the frequency and duration of each fire.

The odor is non-hazardous however, we recommend keeping the room well-ventilated.

Check that all available functions work correctly (See 'Lighting the appliance' in User Instructions for information).

Light the fire on maximum and run for at least 30 mins or until the logs start to glow before turning the appliance to low rate.

NOTE –The flames will start off blue until the appliance has heated properly before turning more yellow.

Spillage Test

A spillage check must be completed. The spillage test is intended to check the draw in the chimney. Close all doors and windows of the room in which the appliance has been installed. Testing is to be done with the appliance on 'high' rate and has been running for at least 10 minutes. Check the appliance for spillage using a smoke match and correct test equipment. Position a lit smoke match inside of the draught diverter opening at the rear of the appliance.

If the appliance and chimney is functioning correctly all smoke will be drawn into the air intake and out of the room. If the smoke does not get drawn into the appliance, allow the appliance to run on maximum rate for a further 10 minutes and repeat the test. If the smoke continues to spill then the unit is to be disconnected and expert advice taken.

Fig.25

Spillage Test Point



Pressure Check

The appliance has been adjusted to give the correct heat inputs as listed in the technical details. No further adjustment is necessary. Always check the inlet pressure and burner pressure.

1. Turn off the gas supply at the gas isolation point.
2. Release the screw on the Inlet Pressure test point on the gas isolation valve/ gas valve and connect a manometer.
3. Check that the measured pressure is as the prescribed supply pressure.
4. Perform the test when the appliance is burning on full rate for working pressure.
5. If the pressure is low, check the gas supply pipes are correctly sized.
6. If the pressure is too high (more than 5mbar over) the appliance may be installed, but the gas supply company should be contacted.
7. Release the screw on the Burner Pressure test point on the burner assembly/ gas valve and connect a manometer.
8. Check that the measured burner pressure at full rate, confirm it is as prescribed.

Note: After checking the pressures and removing the manometers, the screws in the Pressure Test points must be closed, and the system must be checked for gas soundness.

Aeration

IMPORTANT NOTE – The appliance aeration is factory set and under NO circumstances be adjusted by the installer.

As part of the commissioning process the installer is required to fill in commissioning check list in this manual

11. Briefing & Handover to the Customer

Instruct the customer on the full operation of the appliance.

Warn the customer that the fire unit may give off a temporary odor; this is normal running in of the unit and will disappear after a short period of use.

Inform the user that the appliance glass is only to be opened when servicing, and not to disturb the fibre logs as this may disturb the combustion.

Inform the customer that it is recommended that a full service on the appliance and flue checks be carried out annually by competent person/s.

Caution - Make the user aware of the location of the isolation valve and tell the user to close the isolation immediately in case of malfunction / bad performance and to contact the installer in order to prevent dangerous situations.

Instruct the user that the spillage monitoring device fitted to this appliance is designed to shut off the appliance if the evacuation of products of combustion is disturbed. If the appliance repeatedly shuts off after being re-started (as detailed in the 'Lighting instructions' section), a GAS SAFE registered engineer should be contacted to examine the appliance and installation.

Inform the user to always observe the appliance when lighting, once the pilot is lit the main valve then opens allowing gas through to the main burner. The main burner should then light within 6 seconds if this does not happen then the appliance should be turned off allowing 5 minutes before attempting to relight.

Warn the user of the following points:

- not to block vents and to check regularly and remove any blockages.
- not to block the air intake on the appliance.
- that all parts of the appliance will become hot while the appliance is running, so it is recommended that a guard conforming to BS8423: 2002 be used for the protection of young children, aged or infirm persons.
- not to stand too close to the appliance for prolonged periods of time; loose clothing is particularly at risk of burning, and that rubbish cannot be burned in the unit.
- against placing combustible material directly in front of the appliance. Floor coverings such as carpets, are considered to be acceptable.

Ensure the installer details are filled in. Hand over the installation manual to the customer.

12. Servicing & Maintenance

A service of the appliance must be carried out on an annual basis by a qualified person to Local and National Regulations. Failure to service the appliance will invalidate the warranty, a record of the service will be required when processing any warranty claim.

Only carry out maintenance work when the appliance is cold.

Exchangeable Components List

Common Parts:

Slide Version:

- Pilot assembly
- Thermocouple
- Multi-functional control gas valve: TESA
- Logs
- Embers
- Glass seal
- TTB Sensor
- Spark generator/battery holder
- Ignition switch
- Ignition lead

Mertik controls Version:

- Mertik Maxitrol gas valve
- Handset
- Receiver unit
- Pilot assembly
- Gas valve
- Interrupter block
- Thermocurrent cable
- Ignition cable
- TTB Sensor
- Glass seal

Annual Maintenance

Safety precautions must be taken when cleaning the appliance. Ensure appliance is cold before carrying out a service.

Isolate the appliance and disconnect the unit if necessary.

Always test for gas soundness and spillage after refitting the appliance.

Check all logs, pilot burner/ignition unit, for soot or debris deposits. Replace all misplaced logs and retest.

On the failure of pilot burner/ignition or control valve, have the repairs carried out by a competent person.

The door/glass seal should be visually checked during services, if it is deteriorated/split a soundness test should be completed and the seal replaced if the seal is found to be spilling.

Fitting/Changing the battery

New batteries should be fitted on each annual service.

Fig.26

Slide Version

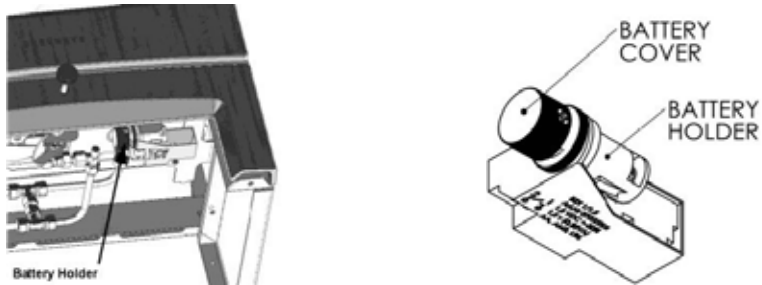

The battery compartment can be accessed under the front of the appliance. Unscrew the Battery cap and remove old battery, fit new battery and replace cap.

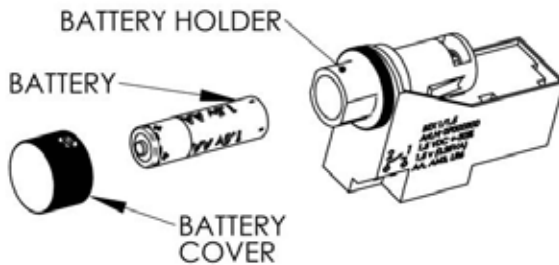

Insert new 1 x AA battery into the holder, negative end first so that the positive end of the battery is exposed and will be located in the battery cover when it is replaced.

Automatic Version

The handset requires 3 x AAA batteries

The receiver unit requires 3 x AA batteries

Suggested Service Procedure

Turn the appliance OFF and isolate the gas supply. Ensure the appliance is fully cold before attempting to start servicing the appliance. No liability can be accepted by Chesneys for injury caused by burning or scolding by a hot appliance. A suggested procedure for servicing is listed below:

- Protect all floor coverings.
- Open front door assembly, remove glass frame fixings and remove glass assembly.
- Carefully remove the Ceramic components including embers
- Use a vacuum cleaner to clean the top of the burners and grate.
- Remove grate.
- The pilot is clearly visible at the front of the burner. Use the vacuum cleaner and a soft brush to clean the pilot assembly. Never modify or bend the thermocouple.
- Turn on the gas supply and check for leaks, check the burners and pilot for good condition and operation.
- Replace grate.
- Refit the glass frame assembly and check seal.
- Check the flue system.
- Light the appliance and test setting pressures and heat input.
- Check the safe operation of the appliance.
- Carry out a spillage test.

Inspecting the Flue / Chimney

The appliance must be serviced by a qualified person in accordance with local and national regulations.

An inspection of the flue / chimney must be carried out on an annual basis or if the appliance is suspected that it is not expelling the emissions correctly. Check the effectiveness of the flue by carrying out a spillage check.

If the appliance fails, a further inspection of the flue must be carried out.

NOTE –To access the flue/chimney the appliance must be isolated and removed.

Remove any debris such as soot, masonry etc. If there are excessive amounts of debris the register plate must be accessed through or be removed to clean the void area. On completion of the servicing/maintenance a spillage test must be carried out once the appliance has been fully reinstalled.

Replacing the Glass Seal

The stove glass seal is a perishable item and should be visually checked during services, if it is deteriorated/split a soundness test should be completed and the seal replaced if the seal is found to be spilling.

If the glass seal is cracked and starting to leak emissions then it must be replaced. The seal is available from most Chesneys suppliers.

Pilot assembly Replacement

The pilot assembly fitted to the appliance should be replaced in line with the terms and conditions of the warranty, failure to do so will invalidate the warranty.

13. Fault Finding

Please follow the correct fault finding information related to the version fire you have: Automatic models, the fault code will be displayed on the handset

Fault Diagnostics		
Fault code	Symptom	Possible Cause
-	<ul style="list-style-type: none"> • 3 short beeps from receiver 	<ul style="list-style-type: none"> • Low receiver batteries
	<ul style="list-style-type: none"> • 5 sec. beep from receiver • Fire is not responding; no ignition 	<ul style="list-style-type: none"> • Faulty Microswitch • Defective wiring of the Motor • Bent Motor Knob
	<ul style="list-style-type: none"> • 5 sec. beep from receiver • Ignition process is interrupted • Fire is not responding; no ignition 	<ul style="list-style-type: none"> • Thermocouple wiring is incorrect • Thermocouple wiring is not connected • ON/OFF switch in "O" (OFF) position Switch on
F04	<ul style="list-style-type: none"> • No pilot flame within 30 sec. • NOTE: After 3 failed ignition sequences wait 1 minute. Retry ignition. 	<ul style="list-style-type: none"> • No gas supply • Air in pilot supply line • No spark • Reversed polarity in thermocouple wiring
	<ul style="list-style-type: none"> • Flame failure during ignition • Motor stays in pilot position 	<ul style="list-style-type: none"> • Not enough thermovoltage • Air in the pilot supply line • Low inlet pressure • Defective thermocouple
F06	<ul style="list-style-type: none"> • 3 failed ignition sequences within 5 minutes • Fire is not responding; no pilot flame 	<ul style="list-style-type: none"> • No gas supply • Air in pilot supply line • No spark • Reversed polarity in thermocouple wiring
	<ul style="list-style-type: none"> • Battery icon flashes on handset display 	<ul style="list-style-type: none"> • Low battery power in handset
	<ul style="list-style-type: none"> • Pilot lit • Main burner fails to ignite and pilot shuts off • Ignition is blocked for 2 minutes 	<ul style="list-style-type: none"> • Gas logs out of position • Gas ports for burner are blocked
	<ul style="list-style-type: none"> • Motor turns to pilot position 	<ul style="list-style-type: none"> • Receiver powered by batteries and receiver temperature exceeds 55 °C • Check proper functioning of air circulation and heat shield
	<ul style="list-style-type: none"> • Motor turns to pilot position • Fan at level 4 for 10 minutes (T>80°C) 	<ul style="list-style-type: none"> • Receiver powered by mains power and receiver temperature exceeds 80 °C • Check proper functioning of air circulation and heat shield
	<ul style="list-style-type: none"> • Fire is not responding; no ignition 	<ul style="list-style-type: none"> • Inlet voltage exceeds 7.25 V • Wrong mains adapter with too high voltage

	<ul style="list-style-type: none"> • Switch panel/touch pad not functioning 	<ul style="list-style-type: none"> • Switch panel/touch pad was deactivated by Receiver • Short in cable or button
	<ul style="list-style-type: none"> • Pilot drops when Motor opens main gas 	<ul style="list-style-type: none"> • Insufficient thermocouple voltage • Thermocouple malfunction • Low inlet gas pressure • Improper thermocouple flame impingement • Carbon buildup on thermocouple • Resistance in thermocurrent circuit too high
	<ul style="list-style-type: none"> • Pilot drops when Motor opens main gas 	<ul style="list-style-type: none"> • Draft too high • Cold junction temperature too high • Magnet unit drops
	<ul style="list-style-type: none"> • It is not possible to increase flame height after ignition 	<ul style="list-style-type: none"> • Receiver powered by batteries and receiver temperature exceeds 55 °C • Receiver powered by mains power and receiver temperature exceeds 80 °C
	<ul style="list-style-type: none"> • Turns to pilot flame position 	<ul style="list-style-type: none"> • No handset communication with receiver for more than 3 hours
	<ul style="list-style-type: none"> • Pilot shuts off after a predefined time • OnDemand Pilot. 	<ul style="list-style-type: none"> • Pilot shuts off after no motor movement for a predetermined time
	<ul style="list-style-type: none"> • Fire is not responding • No electronic control of fire 	<ul style="list-style-type: none"> • Receiver malfunction

Fault Displayed On Handset

Failure code	Symptom	Possible Cause
F04	<ul style="list-style-type: none"> • No pilot flame within 30 sec. • NOTE: After 3 failed ignition sequences F06 shown 	<ul style="list-style-type: none"> • No gas supply • Air in pilot supply line • No spark • Reversed polarity in thermocouple wiring
F06	<ul style="list-style-type: none"> • 3 failed ignition sequences within 5 minutes • Fire is not responding; no pilot flame 	<ul style="list-style-type: none"> • No gas supply • Air in pilot supply line • No spark • Reversed polarity in thermocouple wiring • Check for correct pilot orifice (LPG to NG or vice versa)
F09	<ul style="list-style-type: none"> • Fire is not responding • No electronic control of fire 	<ul style="list-style-type: none"> • Down arrow button was not pressed during synchronization. Receiver and handset are not synced
F46	<ul style="list-style-type: none"> • Fire is not responding • Intermittent response • No electronic control of fire 	<ul style="list-style-type: none"> • No or bad connection between receiver and handset • No power at receiver (batteries low) • Low communication range (mains adapter faulty, handset not communicating with receiver)

14. User Instructions

General

The flue must be fitted in accordance with Local and National Regulations. The flue must not be shared with any other appliance.

It is advised that flue specialist inspect the flue system on an annual basis to ensure that the flue system is sound and the combustion products outlet (terminal) is clear of obstruction.

It is highly recommended that a full service on the appliance be carried out annually by competent person/s.

The gas connection must be in accordance with Local and National Regulations.

Installation and servicing must be carried out by a competent person in line with relevant regulations.

We highly recommend that your fire is turned on at least once a month (for 10 minutes) even during the summer months. This will ensure that the appliance is in good working order. Please check battery levels in both the handset and fire and replace as required.

Chesneys recommend the fitting of a Carbon Monoxide detector that conforms to EN 50291 where ever a gas appliance is installed.

WARNING:

Do not operate the appliance if the glass is broken. Do not to block the air intake on the appliance.

Do not make changes to the appliance.

IMPORTANT:

Fireguards

Due to the nature of the appliance, all parts of the appliance will become hot during normal operation, so it is recommended that in the presence of young children (i.e. in nurseries) the elderly or infirm persons a guard conforming to BS 8423 shall be used.

Do not leave children and persons who cannot judge the consequences of their actions alone with a burning appliance and place the remote control out of reach.

Allow adequate clearances for curtains, pictures, soft furnishings, electrical appliances or any items that may get damaged through heat.

WARNING: Curtains should not be positioned above the appliance. Chesneys advise a minimum clearance of 500mm around the appliance for curtains with an additional allowance being made for curtain movement so that the 500mm perimeter is not compromised. The use of curtain tie backs may be considered as a suitable means to limit curtain movement.

It is also advised against placing combustible materials or soft furnishings directly in front of the appliance.

Blown vinyl wallpaper or coverings must not be used on the chimney breast where the appliance is fitted.

All parts of the appliance become hot while running and therefore the entire appliance should be considered to be a working surface.

It is also advised against placing combustible materials or soft furnishings directly in front or above the appliance. Floor coverings, such as carpets (up to the hearth), are considered to be acceptable.

Do not disturb the fuel bed. Debris from any source, or soot formed, should be removed from time to time.

The spillage monitoring device fitted to this appliance is designed to shut off the appliance if the evacuation of products of combustion is disturbed. If the appliance repeatedly shuts off after being re-started (as detailed in the 'Lighting instructions' section), a GAS SAFE registered engineer should be contacted to examine the appliance and installation.

Ventilation – GB appliances under 7kW (net) do not require permanent ventilation in accordance with BS 5440-2.

NOTE - Other countries may vary ensure ventilation requirements are in accordance with national regulations.

The appliance when lit from cold will start off with a blue flame and will gradually turn more yellow as the flue, logs and appliance heat up.

Important Notes:

- The appliance must not be operated if the appliance glass is broken or has been removed.
- The appliance should always be observed when lighting.
- Improper installation, service, maintenance, adjustment or alterations may cause injury or property damage.
- Do not disturb, add extra fibre logs or embers as this will affect combustion.
- Do not operate the appliance if the fibre logs are damaged.
- The appliance must be installed and maintained by a suitably qualified and registered engineer.
- Ensure this manual remains with the appliance.

Cleaning

Cleaning should only be carried out when the fire is turned off and cold.

This appliance contains no asbestos.

Cleaning Paintwork

Use a clean soft dry brush or a vacuum to remove dirt and debris from the appliance. **DO NOT USE ANY CHEMICALS OR OILS TO CLEAN THE APPLIANCE.**

Cleaning Glass

The glass is specially formulated to withstand very high temperatures use a mild glass cleaner. Use a soft cloth to avoid scratches that may weaken the glass.

Important Notes:

- Ensure the appliance is cold.
- Ensure the glass is clean on both sides as dirt; oils etcetera can etch the glass.
- The glass may develop a white powdery residue on the inside of the stove, which will require to be cleaned on an annual service
- Do not clean with abrasive materials as this can accelerate dirt accumulation and weaken the glass.
- Ensure the door is fitted correctly to avoid spillage.
- Check spillage after carrying out work.

The glass may collect a white powdery residue on the inside of the glass this is a combination of minerals and acids in the gas.

It is known the longer left on the glass the harder it is to remove.

Fuel Bed Components

Wear suitable safety equipment when cleaning the products inside the appliance. It is advised to wear protective gloves and a dust mask conforming to EN 149:2001+A1:2009 FFP3 (available from most DIY shops) when cleaning the logs and embers.

It is necessary to clean the fire if debris or soot deposits have accumulated on the logs. A soft brush is advised to clean the logs and burner unit. The ceramic parts are fragile; care must be taken when handling this product.

Warning – Do not change the fuel bed layout or the quantity of material.

When placing the logs it is important to carefully follow the layout in this manual, the layout has been set to give the best performance and flame picture of the appliance any deviation may cause poor combustion.

The addition of further ceramic components are strictly prohibited, any extra parts supplied are spares for future use.

Ceramic components should last around 2 years in normal use at which time it is recommended that they are replaced. Replacements can be bought from any Chesneys Stockists. State the model number (found on the gas fire data plate). Always ask for genuine Chesneys parts.

This appliance is manufactured by:

Chesneys Limited
194 - 196 Battersea Park Road London
SW11 4ND
Tel: 020 7627 1410

15. Control System Information / Operating instructions

The fire control system fitted to the appliance will be either a Slide Manual Control System or an Automatic Remote Controlled System.

Slide Manual Control System

Operation of the slide manual control system

All operation of the appliance is via the Control Knob on the Front of the appliance. The control knob can be pulled out and pushed into the appliance to turn on, adjust the flame height and turning off. There are two indentations/marks on the control rod that denote the high and low settings.

Fig.27

Control Knob settings

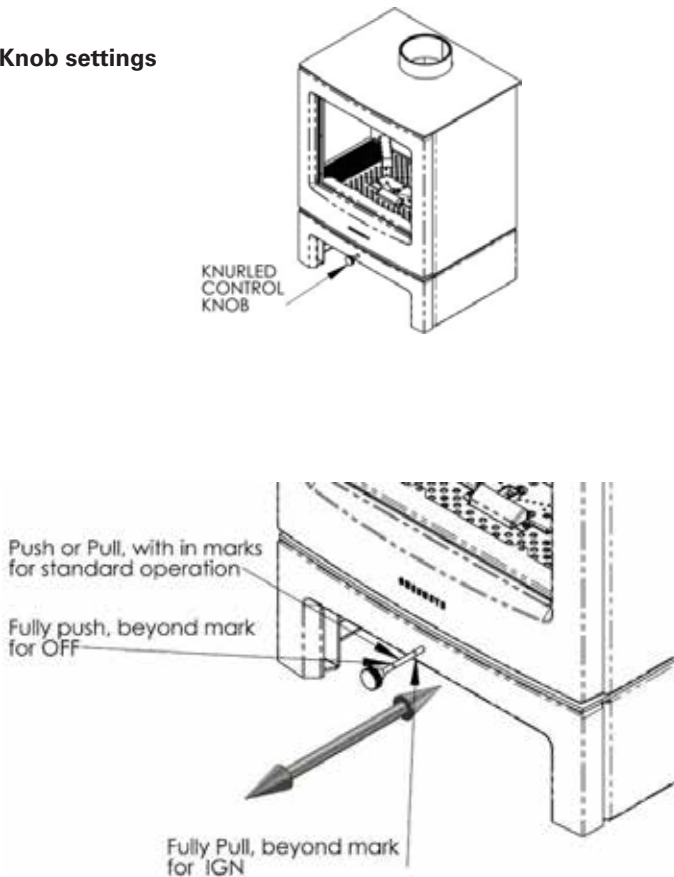

Fig.28

Lighting the Appliance

1. Pull the control knob outwards beyond the second marker and hold.
2. Sparking will occur and pilot flame will light.
3. Continue to hold for up to 15 seconds – when released the pilot should stay alight.
4. With the pilot lit release the control knob – the fire will burn on low flame setting.
5. Increase the flame to high flame for minimum of 30 minutes before turning down to low flame.



Adjusting the flame height

The control knob can be operated between the two markings on the steel rod to turn between high flame and low flame setting.

Low Setting Marker



High Setting Marker



Turning off appliance

Push the control knob fully in towards the front of the appliance. The main burners and the Pilot should now be turned off.

Off Setting Position



Important Note: From initial lighting of the stove it must be run for a minimum period of 30 minutes before the flame can be turned down, this is to allow the appliance and flue to operate effectively.

Restarting the Appliance

If the fire is extinguished or goes out in use, allow 5 minutes before attempting to restart following the lighting sequence.

If the fire shuts itself off repeatedly, do not use the fire, and have the flue and fire checked by a suitably qualified person.

If the appliance is not lighting after 4 ignition attempts, close the gas tap and call the installer.

Operation of the Automatic Remote Controlled System

Batteries – Handset

2 x 1.5 V "AAA" in rear of handset.

Batteries – Receiver

4 x 1.5 V "AA" under removable cover on receiver.

An AC mains adapter may be used instead of batteries.

WARNING

Without using a mains adapter, battery replacement is recommended at the beginning of each heating season.

Old or dead batteries should be removed immediately.

New and old batteries and different brands of batteries should not be used together. Mixing of various batteries can cause the batteries to overheat, leak, and /or explode.

Pairing the Receiver and Handset

The appliance will be supplied with the receiver and handset already paired, the below instructions are only if pairing is required.

1. Insert batteries or connect AC mains power.
2. Place ON /OFF switch (if equipped) to the ON position.
3. The receiver has to learn the handset code:

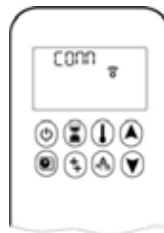

4. Press and hold the receiver's reset button until you hear two beeps.
5. After the second, longer beep, release the reset button.
6. Within 20 seconds press the button ▼ on the handset.
7. Two short beeps confirm the code is set. "conn" is displayed on the handset

NOTE: This is a onetime setting only, and it is not required after changing the batteries in the handset or receiver.

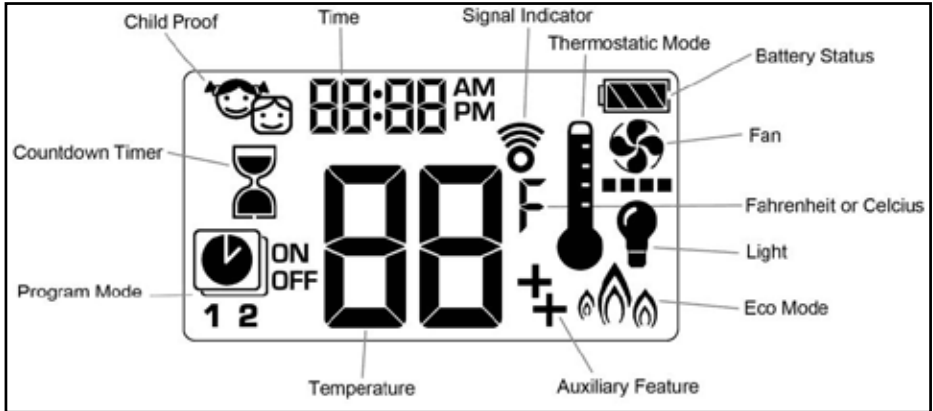

Automatic Burner Control System Operation

10 BUTTON CONTROL



Setting Fahrenheit or Celsius

















To change between °C and °F
press  and  buttons simultaneously.

NOTE: Choosing °F results in a 12 hour clock.
Choosing °C results in a 24 hour clock.

Setting the Time





1. Press  and  buttons simultaneously. Day flashes.
2. Press  or  button to select a number to correspond with the day of the week (e.g. 1 = Monday, 2 = Tuesday, 3 = Wednesday, 4 = Thursday, 5 = Friday, 6 = Saturday, 7 = Sunday).
3. Press  and  buttons simultaneously. Hour flashes.
4. To select hour press  or  button.
5. Press  and  buttons simultaneously. Minutes flashes.
6. To select minutes press  or  button.
7. To confirm press  and  buttons simultaneously, or wait.



Child Proof Mode



ON:

To activate press  and  buttons simultaneously.
 displayed and the handset is rendered inoperable, except for the off function.



OFF:

To deactivate press  and  buttons simultaneously.
 disappears.

Manual Mode (Handset)

To Turn On Fire



Press  and  buttons simultaneously (Two button ignition) until two short beeps and a blinking series of lines confirms the start sequence has begun; release button(s).
Main gas flows once pilot ignition is confirmed.
Handset automatically goes into Manual Mode after main burner ignition.

Standby Mode (Pilot Flame) Handset

Press and hold  button to set appliance to pilot flame.

To Turn Off Fire



Handset



Press  button to turn off.

NOTE: A new ignition is possible after the OFF icon stops flashing.

Flame Height Adjustment



Handset

To Increase flame height press and hold  button.
To decrease flame height or to set appliance to pilot flame, press and holds  button.

Designated Low Fire And High Fire



To go to low fire, double-click ▼ button. **LO** is displayed.

NOTE: Flame goes to high fire first before going to low fire.



To go to low fire, double-click ▲ button. **HI** is displayed.

NOTE: Flame goes to high fire first before going to low fire.

Countdown Timer



ON / SETTING:

1. Press and hold ⌚ button until ⌚ displayed, and hour flashes.
2. To select hour press ▲ or ▼ button.
3. To confirm, press ⌚ button. **Minutes** flash.
4. To select minutes press ▲ or ▼ button.
5. To confirm press ⌚ button, or wait.

OFF:
Press ⌚ button, ⌚ and countdown time disappear.

Thermostatic Mode



ON:

The flame height is then automatically adjusted to achieve the set temperature.

Press button. displayed, preset temperature displayed briefly, and then room temperature displayed.

OFF:

1. Press button.
2. Press or button to enter Manual Mode.
3. Press button to enter Program Mode.



SETTING: Can be programmed to go on and off at specific times at a set temperature.

1. Press button and hold until displayed, temperature flashes.
2. To adjust, set temperature press or button.
3. To confirm press button or wait.

Eco Mode



ON:

Press button to enter Eco Mode. displayed.



OFF:

Press button. disappears.





Flame height modulates between high and low. One cycle lasts approx. 20min.

Program Mode









ON:
Press  button. , 1 or 2, **ON** or **OFF** displayed.



OFF:
1. Press  or  or  button to enter Manual Mode.
2. Press  button to enter Thermostatic Mode.



TEMPERATURE SETTING:

1. Press  button and hold until  flashes. **ON** and set temperature (setting in Thermostatic Mode) displayed.
2. To continue press  button or wait. , **OFF** displayed, temperature flashes.
3. Select OFF temperature by pressing the  or  button.
4. To confirm press  button.







DAY SETTING:

5. ALL flashes. Press ▲ or ▼ button to choose between ALL, SA:SU, 1, 2, 3, 4, 5, 6, 7.
6. To confirm  press button.

ALL selected







ONTIME SETTING (PROGRAM 1):

7. , 1, ON displayed, ALL is displayed shortly and hour flashes.
8. To select hour press ▲ or ▼ button.
9. To confirm press  button. , 1, ON displayed, ALL displayed shortly, and minutes flash.
10. To select minutes press ▲ or ▼ button.
11. To confirm press  button.



OFFTIME SETTING (PROGRAM 1):

12. , 1, OFF displayed, ALL is displayed shortly and hour flashes.
13. To select hour, press ▲ or ▼ button.
14. To confirm press  button. , 1, OFF displayed, ALL displayed shortly, and minutes flash.
15. To select minutes press ▲ or ▼ button.
16. To confirm press  button.

16. Installation / Commissioning Record/Dealer Details

Dealer Name & Address				
Customer Name & Address				
INSTALLER INFORMATION				
Installation Date				
Installer Name				
Company				
Address				
Gas Safe Reg No.				
APPLIANCE INFORMATION				
Model Name				
Stove Serial No.				
Burner Serial No.				
Gas Type	Natural Gas		LPG	
Flue Type	Flue Liner		Linerless Kit	
Flue Diameter				
COMMISSIONING CHECKLIST				
Gas Inlet pressure mbar				
Gas Working pressure mbar				
Gas Rate m3/h				
Flue Flow Test	PASS		FAIL	
Spillage Test	PASS		FAIL	
Ventilation Requirements met	PASS		FAIL	
Approved Carbon Monoxide Detector fitted & tested	PASS		FAIL	
Engineer Signature			Date	/ /

17. Annual Service Record

Annual Service Record Year 1
Gas Safe Registered Engineer:
Contact No.:
Gas Safe Register No.:
Date of Service:
Componetes repalced: Pilot assembly replaced?

Annual Service Record Year 2
Gas Safe Registered Engineer:
Contact No.:
Gas Safe Register No.:
Date of Service:
Componetes repalced: Pilot assembly replaced?

Annual Service Record Year 3
Gas Safe Registered Engineer:
Contact No.:
Gas Safe Register No.:
Date of Service:
Componetes repalced: Pilot assembly replaced?

Annual Service Record Year 4
Gas Safe Registered Engineer:
Contact No.:
Gas Safe Register No.:
Date of Service:
Componetes repalced: Pilot assembly replaced?

Annual Service Record Year 5
Gas Safe Registered Engineer:
Contact No.:
Gas Safe Register No.:
Date of Service:
Componetes repalced: Pilot assembly replaced?

Annual Service Record Year 6
Gas Safe Registered Engineer:
Contact No.:
Gas Safe Register No.:
Date of Service:
Componetes repalced: Pilot assembly replaced?

Annual Service Record Year 7
Gas Safe Registered Engineer:
Contact No.:
Gas Safe Register No.:
Date of Service:
Componetes repalced: Pilot assembly replaced?

Annual Service Record Year 8
Gas Safe Registered Engineer:
Contact No.:
Gas Safe Register No.:
Date of Service:
Componetes repalced: Pilot assembly replaced?

Annual Service Record Year 9
Gas Safe Registered Engineer:
Contact No.:
Gas Safe Register No.:
Date of Service:
Componetes repalced: Pilot assembly replaced?

Annual Service Record Year 10
Gas Safe Registered Engineer:
Contact No.:
Gas Safe Register No.:
Date of Service:
Componetes repalced: Pilot assembly replaced?

Annual Service Record Year 11
Gas Safe Registered Engineer:
Contact No.:
Gas Safe Register No.:
Date of Service:
Componetes repalced: Pilot assembly replaced?

Annual Service Record Year 12
Gas Safe Registered Engineer:
Contact No.:
Gas Safe Register No.:
Date of Service:
Componetes repalced: Pilot assembly replaced?

18. Chesneys Warranty Information

Warranty/Guarantee Terms:

Your Chesneys gas stove is covered by a standard 1 year manufacturer warranty. An extended 5 year warranty is available following registration of the appliance within 28 days of installation. All warranties are subject to full terms and conditions, including annual servicing, all consumables items are excluded from warranty. Proof/records of servicing will be required when making any claims under warranty.

To validate and start your warranty please fill out this form and send it back to:

WARRANTY REGISTRATION
CHESNEYS GROUP LTD UNITS
12-16 ELDON ROAD, BEESTON,
NOTTINGHAM,
NG9 6DZ

Alternatively, log on to: <https://chesneys.co.uk/warranty-registration> and complete the online form.

In the event of a breakdown or claim you are required to contact the installer/trade stockist. They will need to investigate the matter and process the claim on your behalf if required.

The extended warranty must be registered within 28 days of installation of the appliance. Failure to register within this time period will result in the warranty reverting to the standard 1 year from date of installation.

To register you must provide the full serial number of the appliance.

This is clearly shown on the;

- Stove packaging
- Appliance data plate

Please also be advised that your appliance must be serviced annually to honor your warranty. The appliance must be serviced by a Gas Safe Registered engineer in accordance with the manufacturer's instructions. Replacement of the pilot assembly and spillage monitoring device (TTB) is a requirement of the warranty conditions, these items are classed as consumable items which are not covered by the warranty.

Failure to have the stove serviced voids the extended warranty terms.

Service details must be recorded in the Installation and User Manual which must be available for inspection once making a warranty claim.

The cost of annual servicing is not included in the warranty.

Full terms of conditions can be found at:

<https://chesneys.co.uk/warranty-registration>



Chesneys Warranty Registration Form

All items are required:

Your Details	
Name	
Address	
Postcode	
Email	

Purchase Details	
Purchased From	
Purchase Date	

Product Details	
Product Name	
Product Colour	
Gas Type	Natural Gas / LPG
Stove Serial Number	
Burner Serial Number	

Installation Details	
Installed by	
GAS SAFE registration no.	
Installation date	
Flue Type	Liner / Linerless Kit

