

CHESNEY'S

powered by



Electric Fire Basket & Electric Stove User Manual



Thank you for choosing this Chesney's electric fire. Please read this information guide carefully to be able to safely install, use and maintain your product.

Front cover upper image shows Chesney's Electric Fire with Soho Basket and Spherical Fire Dogs.
Lower image shows the Salisbury Electric Stove in black paint finish

CHESNEY'S

powered by



Contents

1. Important Safety Advice	2
2. General Information	4
3. Installation Instructions	5
4. Operating the Fire	7
5. Maintenance	10
6. Troubleshooting	20
7. Additional Information	22
8. Warranty Registration	25

1. Important Safety Advice

WHEN USING ELECTRICAL APPLIANCES, BASIC PRECAUTIONS SHOULD ALWAYS BE FOLLOWED TO REDUCE THE RISK OF FIRE, ELECTRICAL SHOCK AND INJURY TO PERSONS, INCLUDING THE FOLLOWING:

1. OVERHEATING

WARNING: IN ORDER TO AVOID OVERHEATING, DO NOT COVER THE HEATER. DO NOT PLACE MATERIAL OR GARMENTS ON, OR OBSTRUCT THE AIR CIRCULATION AROUND THE APPLIANCE. THE HEATER CARRIES A DO NOT COVER WARNING.

2. DAMAGE

IF THE APPLIANCE IS DAMAGED, CHECK WITH THE SUPPLIER BEFORE INSTALLATION AND OPERATION. IF THE SUPPLY CORD IS DAMAGED IT MUST BE REPLACED BY THE MANUFACTURER OR SERVICE AGENT OR A SIMILARLY QUALIFIED PERSON IN ORDER TO AVOID A HAZARD.

3. LOCATION

DO NOT USE OUTDOORS.

DO NOT USE IN THE IMMEDIATE SURROUNDINGS OF A BATH, SHOWER OR SWIMMING POOL.

DO NOT LOCATE THE FIRE IMMEDIATELY BELOW A FIXED SOCKET OUTLET OR CONNECTION BOX.

ENSURE THAT FURNITURE, CURTAINS OR OTHER COMBUSTIBLE MATERIAL ARE POSITIONED NO CLOSER THAN 1 METRE FROM THE APPLIANCE.

ALTHOUGH THIS HEATER CONFORMS WITH SAFETY STANDARDS, WE DO NOT RECOMMEND ITS USE ON DEEP PILE CARPETS OR ON LONG HAIR TYPE OF RUGS.

4. PLUG POSITIONING

THE APPLIANCE MUST BE POSITIONED SO THAT THE PLUG IS ACCESSIBLE.

KEEP THE SUPPLY CORD AWAY FROM THE FRONT OF THE APPLIANCE.

5. USE OF OTHER CONTROLS

DO NOT USE THIS HEATER IN SERIES WITH A THERMAL CONTROL, A PROGRAM CONTROLLER, A TIMER OR ANY OTHER DEVICE THAT SWITCHES ON THE HEAT

AUTOMATICALLY, SINCE A FIRE RISK EXISTS WHEN THE HEATER IS ACCIDENTALLY COVERED OR DISPLACED.

6. UNPLUGGING

IN THE EVENT OF A FAULT UNPLUG THE DEVICE.
UNPLUG THE DEVICE WHEN NOT REQUIRED FOR LONG PERIODS.

7. OWNER/USER

THIS APPLIANCE CAN BE USED BY CHILDREN AGED FROM 8 YEARS AND ABOVE AND PERSONS WITH REDUCED PHYSICAL, SENSORY OR MENTAL CAPABILITIES OR LACK OF EXPERIENCE AND KNOWLEDGE IF THEY HAVE BEEN GIVEN SUPERVISION OR INSTRUCTION CONCERNING USE OF THE APPLIANCE IN A SAFE WAY AND UNDERSTAND THE HAZARDS INVOLVED. CHILDREN SHALL NOT PLAY WITH THE APPLIANCE.

CLEANING AND USER MAINTENANCE SHALL NOT BE MADE BY CHILDREN WITHOUT SUPERVISION.
CHILDREN OF LESS THAN 3 YEARS SHOULD BE KEPT AWAY UNLESS CONTINUOUSLY SUPERVISED. CHILDREN AGED FROM 3 YEARS AND LESS THAN 8 YEARS SHALL ONLY SWITCH ON/OFF THE APPLIANCE PROVIDED THAT IT HAS BEEN PLACED OR INSTALLED IN ITS INTENDED NORMAL OPERATING POSITION AND THEY HAVE BEEN GIVEN SUPERVISION OR INSTRUCTION CONCERNING USE OF THE APPLIANCE IN A SAFE WAY AND UNDERSTANDING THE HAZARDS INVOLVED. CHILDREN AGED FROM 3 YEARS AND LESS THAN 8 YEARS SHALL NOT PLUG IN, REGULATE AND CLEAN THE APPLIANCE OR PERFORM USER MAINTENANCE.

CAUTION - SOME PARTS OF THIS PRODUCT CAN BECOME VERY HOT AND CAUSE BURNS. PARTICULAR ATTENTION HAS TO BE GIVEN WHERE CHILDREN AND VULNERABLE PEOPLE ARE PRESENT.

8. ELECTRICITY

WARNING – THIS APPLIANCE MUST BE EARTHED.
THIS APPLIANCE MUST BE USED ON AN AC ~ SUPPLY ONLY AND THE VOLTAGE MARKED ON THE APPLIANCE MUST CORRESPOND TO THE SUPPLY VOLTAGE.
BEFORE SWITCHING ON, PLEASE READ THE SAFETY ADVICE AND OPERATING INSTRUCTIONS.

2. General Information

Only use filtered water in this appliance.

This model is designed to be free standing and is normally positioned near a wall, on a non combustible surface.

Always ensure the appliance is sitting on a level, non-combustible surface.

Please note: Used in an environment where background noise is very low, it may be possible to hear a sound which is related to the operation of the flame effect. This is normal and should not be a cause for concern.

If this product experiences a power surge for whatever reason the product may cut-out. This is a normal safety feature and the product will resume operation after 30 seconds.

Once installed, never move this appliance or lay on its back, without draining the water from sump and water tank.

If you intend not using the appliance for longer than 2 weeks, drain the water from sump and water tank and dry the sump.

The water tank, sump, sump lid, tank cap and air filters must be cleaned once every two weeks, particularly in hard water areas.

The appliance should never be operated if the lamps are not working.

The lamps should be regularly inspected as described under 'Maintenance' and 'Changing lamps'.

3. Installation Instructions

This section describes how to set up your fire.

BEFORE YOU START

1. Ensure that all packing items are removed (read any warning labels carefully) and retain all packing for possible future use e.g. in the event of moving house or returning the appliance to your supplier.
2. Before connecting to the mains supply, check that the supply voltage is the same as that stated on the appliance.

INSTALLATION

Electric Fire Baskets: Place the appliance against a wall.

Connect the power cable to the appropriate power connector at the back of the appliance and plug the power cable into a 13amp/240volt outlet. Do not yet switch the appliance on.

Electric Stoves: Place the stove in to position allowing a minimum of 125mm all around the stove for ventilation.

Connect the power cable to the appropriate power connector at the back of the fire and plug the power cable into a 13amp/240volt outlet. Do not yet switch the appliance on.

Connecting the Transducer Unit + Lamps

1. Release the two red tabs by turning them by 90° (see Fig.1).
2. Lift out the Sump Nozzle (Fig.2).
3. Insert lamps into lamp holders (Fig.3), carefully locating the pins into the holes (Fig.4).
4. Push lamps firmly into place.
5. Place the Transducer Unit into the sump and join the cable to the connector on the sump (Fig 5).
6. To ensure that the Transducer Unit is correctly placed in the sump, the tab on the Transducer Unit should be lined up with the moulded recess in the sump (Fig 5a).
7. Ensure that the cable is not placed above the disc on the Transducer Unit (Fig 5b). To prevent the cable becoming pinched between the nozzle and the sump, place the cable in the slot in the wall of the sump.
8. Replace the Sump Nozzle and secure it by turning the two red tabs by 90° (Fig 6).

Filling the Water Tank

9. Place Water Tank in sink and remove cap (turn anti-clockwise to open) (Fig 7).

10. Fill Water Tank with **filtered tap water only**. This is necessary to prolong the life of the flame and smoke effect producing unit. The water should be filtered through a conventional domestic water filter unit and the filter should be replaced regularly. Distilled water must not be used.

11. Screw the cap back on – **do not overtighten**.

12. Place the Water Tank in the Sump, with the tank cap facing down and the flat side of the tank facing outward (Fig 8).

Assembling the fire

13. Place the Fuelbed on top of the Water Tank.

The appliance is now ready for use.

4. Operating the Fire

This section describes how to activate your fire using either the manual controls or remote control.

MANUAL CONTROLS

The manual controls are located beneath the hinged flap. (See Fig.9 for Manual Control lay out).

Switch 'A':- Controls the electricity supply to the Fire.

Note: This switch must be in the 'ON' (I) position for the Fire to operate.

Switch 'B':- Press  once to turn on the flame effect. This will be indicated by an audible beep. Although the main lights operate immediately it will take a further 30 seconds before the flame effect starts.

(Electric Stove models only)

Press  again to give flame effect and half heat. This will be indicated by two beeps.

Press  again to give flame effect and full heat. This will be indicated by three beeps.

Press  again to return to flame effect only. This will be indicated by one beep.

Press  to put fire in to standby mode. This will be indicated by one beep.

Control Knob 'C':- Controls the Thermostat setting. **(Electric Stove Models only)**. Turning the control knob to the left will decrease the temperature setting, turning the control knob to the right will increase the temperature setting.

Control Knob 'D':- Controls the intensity of the flame effect. Turning the control knob to the left increases the flame effect, turning the control knob to the right will decrease the flame effect.

SETTING THE THERMOSTAT (Electric Stove models only)

Ensure the fire is plugged in and switch it on to the full heat setting. Turn the Control Knob 'C' fully to the right (max temperature setting) to warm the room rapidly. When the room temperature has reached the desired level, turn the thermostat knob back slowly until you hear the thermostat just click off. The heater will then maintain the room temperature at the chosen level.

Note: Should your heater fail to come on when the thermostat is at a low setting, this may be due to the room temperature being higher than the thermostat setting.

THERMAL SAFETY CUT-OUT (Electric Stove models only)

A thermal safety cut-out is incorporated in the fan heater to prevent damage due to overheating. This can happen if the heat outlet was restricted in any way. If the cut-out operates, unplug the heater from the socket outlet and allow approximately 10 minutes before reconnecting. Before switching the heater back on remove any obstruction that may be restricting the heat outlet, then continue normal operation.

Caution: In order to avoid a hazard due to inadvertent resetting of the thermal cutout, this appliance must not be supplied through an external switching device, such as a timer, or connected to a switch that is regularly switched on and off by the utility.

GETTING THE DESIRED FLAME EFFECT

1. The flame control knob 'D' (Fig.9) may be turned up or down to give a more realistic effect.
2. Generally the flames appear more realistic when the flame control is turned down.
3. Give the flame generator time to react to changes you may make.
4. The appliance will use less water if the flame effect is set to a lower level (control knob 'D').
5. Do not tilt or move the appliance while there is water in the tank or sump.
6. Make sure that the appliance is on a level floor.

REMOTE CONTROL OPERATION

On the control panel, Switch A (see Fig. 9) must be in the 'ON' (I) position in order for the remote control to operate.

There are 3 buttons on the remote control. (See Fig.11) To operate correctly the remote must be pointed towards the front of the grate. (See Fig 16). The remote control functions are as follows:



Press once to turn on Flame effect only.
This will be indicated by one beep.





(Electric Stove models only)

Press once to turn on Half Heat and Flame Effect.

This will be indicated by two beeps.

Press again to turn on Full Heat and Flame Effect.

This will be indicated by three beeps.

To switch from Half or Full Heat to Flame Effect only, press  followed by 



Standby.

This will be indicated by one beep.

5. Maintenance

GENERAL TIPS

Only use filtered tap water in this appliance.

Always ensure that the appliance is sitting on a level surface.

If you intend not using the appliance for longer than 2 weeks, remove and empty the sump and water tank.

Once installed, never move this appliance or lay on its back, without draining the water from sump and water tank.

The appliance should never be operated if the lamps are not working.

The lamps should be regularly inspected as described under 'Changing lamps'.

FILLING THE WATER TANK

When the water tank is empty, the flame and smoke effect shuts off and you will hear 2 audible beeps, follow these steps.

1. Press Switch 'A' to **(0)** (See Fig.9).

2. Gently lift out the fuelbed and carefully set aside.

3. Remove the water tank by lifting upwards and outwards.

4. Place the water tank in sink and remove cap, Anti-clockwise to open (Fig 7).

5. Fill tank with **filtered tap water only**. This is necessary to prolong the life of the flame and smoke producing unit.

The water should be filtered through a conventional domestic water filter unit and the filter should be replaced regularly.

6. Screw the cap back on, do not over tighten.

7. Return the tank to the sump, with the tank cap facing down and the flat side of the tank facing outward (Fig 8).

8. Gently place the fuelbed back into position.

9. Press Switch 'A' to 'ON' **(I)** position (See Fig.9).

CHANGING LAMPS

If the flame and smoke effect appears grey or colourless it may be that one or more lamps have failed.

You can check for lamp failure as follows.

1. Leaving the flame effect on, lift out the fuelbed and water tank.

2. It should be possible to view the lamps with the nozzle in place and observe which one needs to be changed.

3. Put Switch 'A' in the 'OFF' **(0)** position, and unplug the fire from the mains.

4. Leave the appliance for 20 minutes to allow the lamps to cool down before removing them.
5. Remove the sump as described in the Cleaning Section.
6. Remove the defective lamp, by gently lifting vertically and disengaging the pins from the lamp holder,
(See Fig.3 and 4).
Replace with a Dimplex OPTIMYST, 12V / 45W, Gu5.3 base, 8° beam angle, coloured lamp (Purchased from the website:
<http://spares.dimplex.co.uk>).
7. Carefully insert the two pins of the new lamp into the two holes in the lamp holder. Push firmly in place.
(See Fig.3 and 4).
8. Replace the sump, nozzle, water tank and fuelbed.

CLEANING

Warning – Always press Switch ‘A’ to the ‘OFF’ (0) position (See Fig.9) and disconnect from the power supply before cleaning the fire.

We recommend cleaning the following components once every 2 weeks, particularly in hard water areas:-

Water Tank, Sump, Nozzle, Tank cap and seal, Air filter.

For general cleaning use a soft clean duster – never use abrasive cleaners.

To remove any accumulation of dust or fluff, the soft brush attachment of a vacuum cleaner should occasionally be used.

Water tank

1. Remove water tank, as described earlier, put into sink and empty water.
2. Using the supplied brush gently rub the inside surfaces of the cap paying particular attention to the rubber ring in the outer groove and the centre rubber seal.
3. Put a small quantity of washing up liquid into the tank, refit the cap and shake well, rinse out until all traces of washing up liquid are gone.
4. Refill with filtered tap water only, replace the cap, do not overtighten.

Sump

1. Press Switch ‘A’ to the ‘OFF’ (0) position.
2. Gently lift out the fuelbed and place carefully on the ground.
3. Remove the water tank by lifting upwards.
4. Disconnect the electrical connector, located on the right side of the sump (See Fig.5).

5. Release the right and left sump locking tabs by turning 90° (See Fig.1).
6. Lift off the Nozzle (See Fig.2). This allows the sump to be lifted completely from its location.
7. Gently lift up the sump, taking care to keep level so as not to spill any water. Sit the assembly in the sink.
8. Lift out the transducer and carefully tilt, as shown, so that the liquid drains out of the sump (See Fig.12).
9. Put a small amount of washing up liquid into the sump, and using the supplied brush, gently clean all surfaces in the sump and gently clean the transducer including the metal discs located in the top grooved surface (See Fig.13).
10. When cleaned, thoroughly rinse the sump with clean water to remove all traces of washing up liquid.
11. Clean the Nozzle with the brush and flush out thoroughly with water (See Fig.14).
12. Reverse the above steps to reassemble.

Air filter

1. Gently lift out the fuelbed and place carefully on the ground.
2. Gently slide the air filter upwards out of its plastic holder (See Fig.15).
3. Gently rinse with water in the sink and dry with fabric towel before returning.
4. Replace the filter making sure that the coarse black filter is facing the front of the fire.
5. Replace the fuelbed.

Fig.1

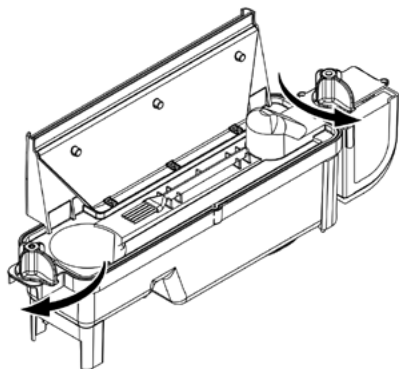

Fig.2

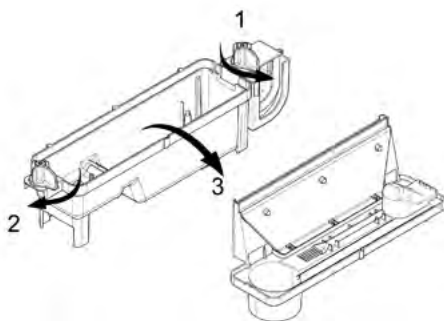

Fig.3

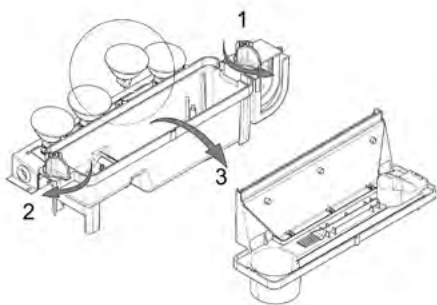

Fig.4

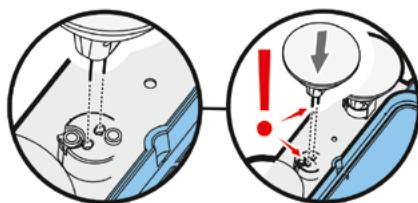

Fig.5

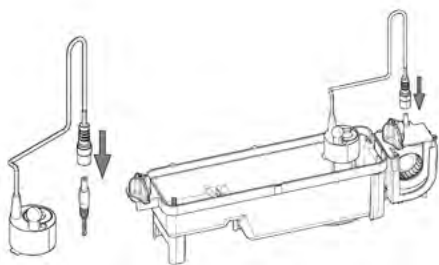

Fig.5a

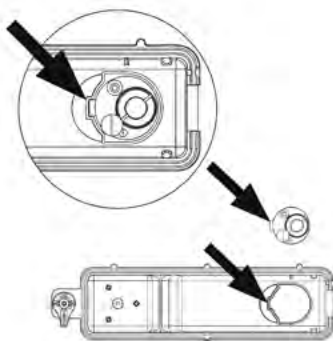

Fig.5b

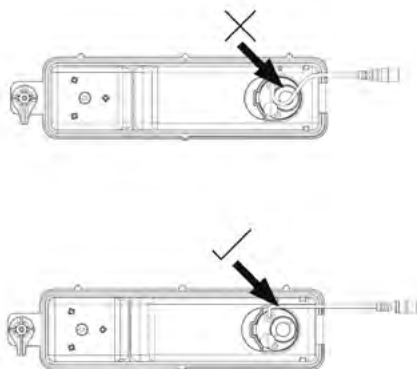

Fig.6

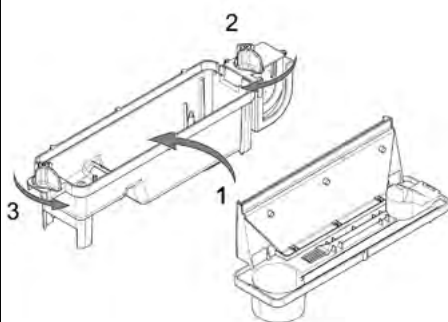

Fig.7

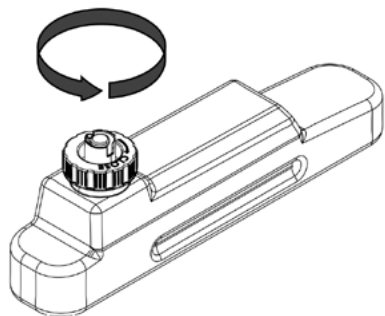

Fig.8

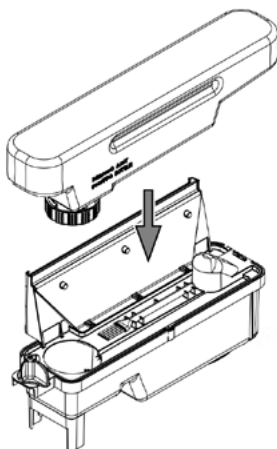

Fig.9

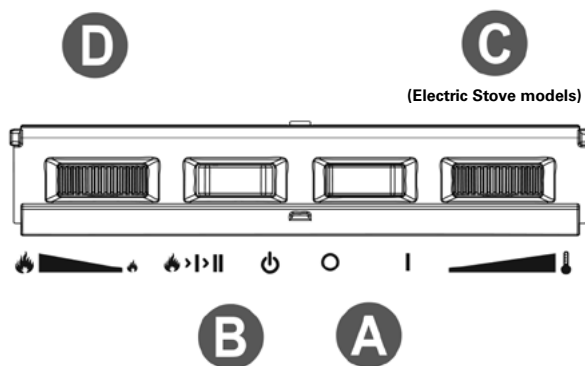

Fig.10

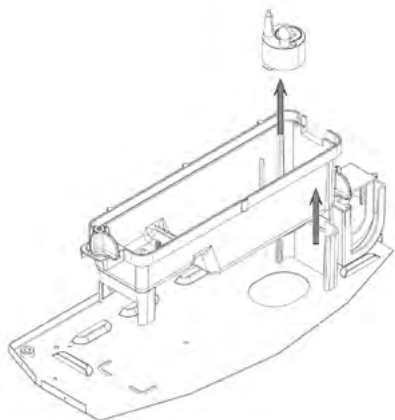

Fig.11

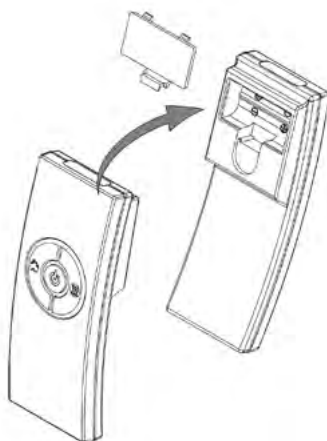

Fig.12



Fig.13

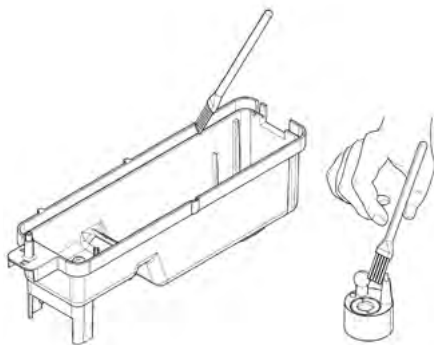

Fig.14

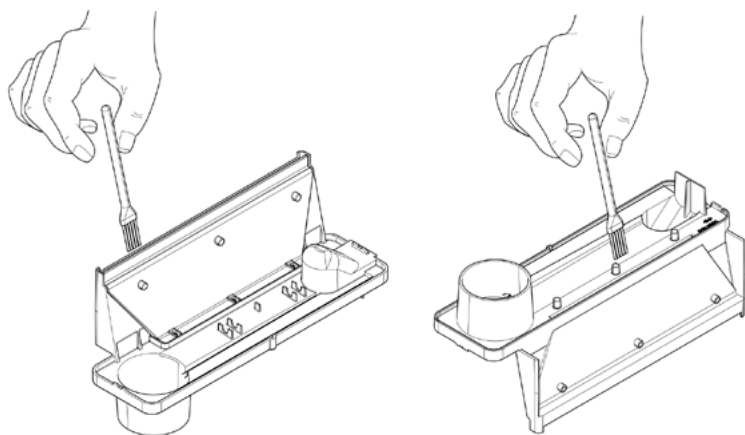

Fig.15

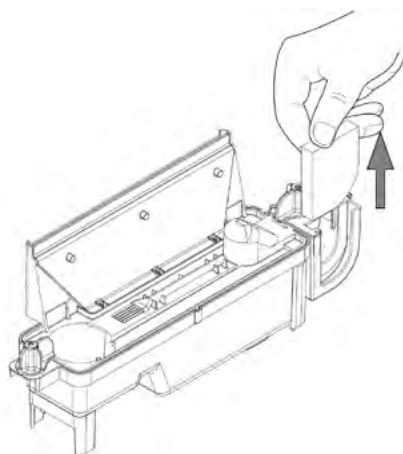
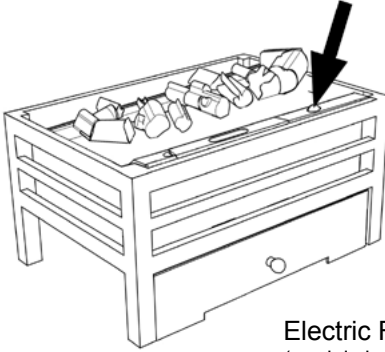

Fig.16

REMOTE CONTROL SENSOR



Electric Fire Basket
(model shown: Soho Freestanding Basket)

Electric Stove
(model shown: Salisbury)

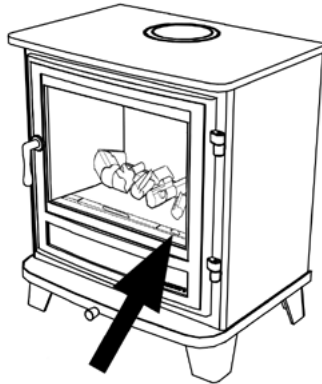

REMOTE CONTROL SENSOR

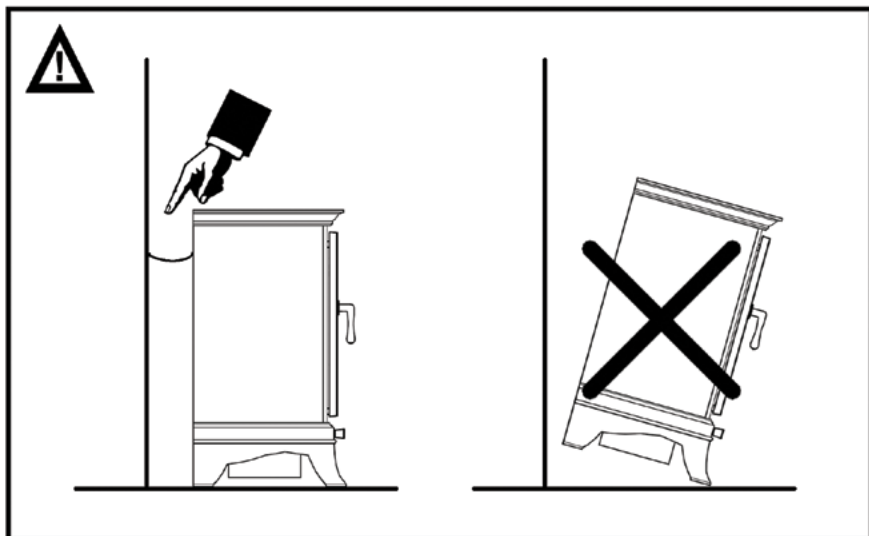

Use the fixing chain provided to secure the appliance to a rear wall

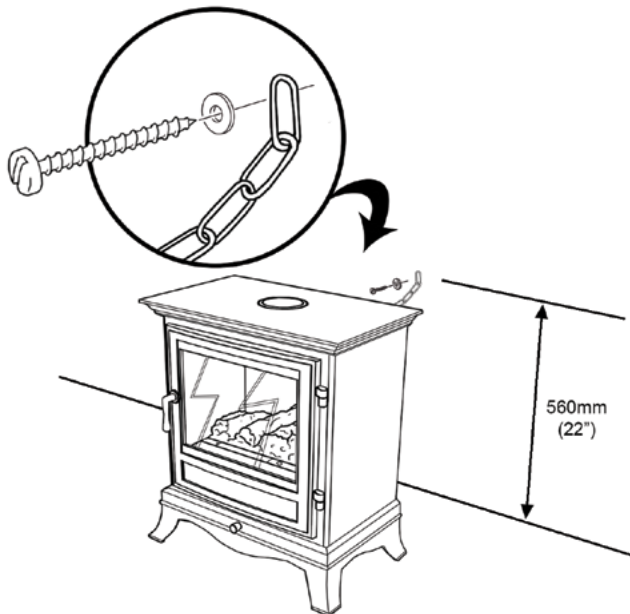

6. Troubleshooting

SYMPTOM	CAUSE	CORRECTIVE ACTION
The flame effect will not start.	Mains plug is not plugged in.	Check plug is connected to wall socket correctly.
	Low water level.	Check that the water tank is full and there is water in the sump.
	Low voltage connector not connected properly. (See Fig.5)	Check that the connector is inserted correctly. (See Fig.5)
	The Transducer Unit is not sitting correctly in the sump	Ensure the Transducer is sitting down into the moulded recess in the sump
The flame effect is too low.	Flame effect control knob is set too low. (See Fig.9)	Increase level of flame by turning Control knob 'D' to the left slowly (See Fig.9).
	The Metal Disc in the transducer might be dirty (See Fig.13)	Clean the Metal Disc with soft brush supplied (See Fig.13). See 'Maintenance' for a step by step procedure.
	The wire from the Transducer Unit is sitting over the metal disc	Direct the wire to the back of the sump and make sure it sits into the side slot exiting the sump.

SYMPTOM	CAUSE	CORRECTIVE ACTION
Unpleasant smell when unit is used.	<p>Dirty or stale water.</p> <p>Using unfiltered tap water.</p>	<p>Clean the unit as described under maintenance.</p> <p>Use only filtered tap water.</p>
The flame effect has too much smoke.	Flame effect setting is too high.	Turn the flame effect Control knob 'D' to the right, about $\frac{1}{4}$ a turn, at a time. Give the flame generator some time to adjust to the new setting (See Fig.9).
Main lamps are not working and there are no flames or smoke.	There is no water in the water tank.	<p>Follow instructions under Maintenance, 'Filling the water tank'.</p> <p>Check the plug is connected to the wall socket correctly and that Switch 'A' Fig.9 is in the 'ON' (I) position.</p> <p>Troubleshooting</p>
Glass misting upon start up <i>(Electric stove models only).</i>	Condensation build up.	Turn the flame effect control knob 'D' down to minimum (see Fig.9) and open the door slightly to allow air flow while the unit is warming up. Close the door once the glass is clear and unit warm. Repeat if necessary.

7. Additional Information

AFTER SALES SERVICE

Your product is guaranteed for one year from the date of purchase. Within this period, we undertake to repair or exchange this product free of charge (excluding lamps & subject to availability) provided it has been installed and operated in accordance with these instructions. Your rights under this guarantee are additional to your statutory rights, which in turn are not affected by this guarantee.

Should you require after sales information or assistance with this product please go to www.dimplex.co.uk and select "Customer Support" or ring the help desk on: 0844 879 3588 (UK) or 01 842 4833 (R.O.I.) Please retain your receipt as proof of purchase.

RECYCLING



For electrical products sold within the European Community -
At the end of the electrical products useful life it not be disposed of with household waste.
Please recycle where facilities exist. Check with your Local Authority or retailer for recycling advice in your country.

PATENT / PATENT APPLICATION

Products within the Optimyst range are protected by one or more of the following patents and patent applications:

Great Britain GB 2402206, GB 2460259, GB 2460453 , GB 2418014, GB 2465738, GB 2449925,
GB 2465537 , GB 2455277 , GB1020534.2, GB1020537.5, GB1110987.3
United States US 7967690, US 2010299980, US 2011062250, US 2008028648,
US 13/167,042
Russia RU2008140317
European EP 2029941, EP 2201301, EP 2315976, EP 1787063, EP07723217.1 , EP11170434.2,
EP 11170435.9
China CN 101883953, CN 200980128666.2, CN 101057105, CN 101438104
Australia AU 2009248743, AU 2007224634
Canada CA 2725214, CA 2579444, CA 2645939
International Patent Application WO 2006027272
South Africa ZA 200808702
Mexico MX 2008011712
Korea KR 20080113235
Japan JP 2009529649
Brazil BR P10708894-9
India IN 4122/KOLNP/2008
New Zealand NZ 571900

© Chesney's MMXV December 2015

Opti-myst is a trade mark of GDC Group Ltd.

All rights reserved. Material contained in this publication may not be reproduced in whole or in part, without prior permission in writing of Chesney's.



The product complies with the European Safety Standards EN60335-2-30 and the European Standard Electromagnetic Compatibility (EMC) EN55014, EN60555-2 and EN60555-3. These cover the essential requirements of EEC Directives 2006/95/EC and 2004/108/EC.

- Notes -

- Notes -

8. Warranty Registration

To validate and start your warranty please fill out this form and send it back to:

Chesney's Warranty Registration,
521 Battersea Park Road,
London,
SW11 3BN

Alternatively, log on to: <https://secure.chesneys.co.uk/warranty/registration.asp>
and complete the online form.

All items are required:

Your Details	
Name	
Address	
Postcode	
Email address	

Purchase Details	
Purchased From	
Purchase Date	

Product Details	
Appliance name	
Appliance colour	
Serial number	



